

FARM AND BARN



WWW.RAMMFENCE.COM | 1.800.853.1611

DEBBIE'S LETTER TO YOU!



Welcome to all of our customers and friends! You have made RAMM Horse Fencing and Stalls the **NUMBER 1 CHOICE** for fencing, stalls and equipment! I personally want to thank you for telling other horse, cattle and exotic animal owners about us! We cannot tell you how wonderful it is to be a part of your projects and your lives!

For over 24 years we have been providing barn and farm products for your horses and animal needs. We consider it a joy to share our common passion with you daily! At the RAMM farm we have been using our products since we started in 1988. We know that durability and long lasting products are important when it comes to taking care of your horses and animals. But don't let me tell you, our customers agree and you will see their good comments throughout this guide!

OUR NEWEST product line is sure to help you with any of your fencing issues! **The HIGH IMPACT** Flex Fence Series is sure to give you more than you expect! When our customers ask us to provide them with a quality, long lasting and easy to install flex fence, we listened to their requests! After 10 years of testing **RAMM's HIGH IMPACT**, we can now offer you unsurpassed performance, and a **LIFE TIME** limited mfg. warranty! So easy to put up that a 55 year old grandmother shows you how on our installation video and/or manual! This should be a big encouragement to anyone

that would like to install fencing for themselves! **HIGH IMPACT** is proudly **made in the USA**. Additionally we carry a large line of electric, tape, braid, woven wire, and PVC for your farm. You'll find all of your fencing accessories, hardware and posts here. We have a fence for your horses, cattle or exotics that meets every need and budget!

Would you like a **free estimate or advice on your project**? Call our toll free number at **1-800-416-1958**. A member of our staff will offer all of the help that you will need to complete your project. You can fax (419) 825-2433 or email us at ramm@rammfence.com. We look forward to helping you!

If you are in the market for new stalls or looking to update existing stalls, RAMM is the one stop shop for you! Our stall manufacturing plant, located right in Archbold, Oh, fabricates **Welded Stalls at budget-friendly prices or one-of-a-kind Custom Stalls**. We carry multiple options for doors, window grills and hardware to complete your barn! No stall is complete without feeders, stall mats and water systems. Our stalls and accessories will help to keep your horses comfortable and healthy with the extra benefit of a beautiful look to complement your barn!

Have you visited our web sight lately? Just go to www.rammfence.com and you will not only find helpful information on our fencing, stalls and equipment, but also informative articles to help you with your farm and horses. If you have a product or horse question and would like to

talk, click onto "**Resource Center**" and "**Ask Debbie**". I will personally email you with ideas and answers for your particular project!

By the way, be sure to look for us on **Face book, Twitter and G+**. There is a whole world of interesting conversation going on with horse owners and RAMM! Sign up for our free e-newsletter or subscribe to our '**ASK DEBBIE**' Blog. We will keep you in the loop on what other horse owners think about and do, what's 'hot' and what's 'not'! In addition, we will send you informative articles that will help you with your horses as well as your farm and barn! For more details go to www.rammfence.com.

From myself, as well as our family and staff, we **thank** all of our customers who have touched our lives so deeply. We are privileged to talk with you just like a neighbor down the road. We are all thankful for all of your encouragement and great comments. You remind us daily that we are especially fortunate to be able to share a common passion: our horses and animals!

Ride long, laugh often...

Debbie Disbrow
Founder and President of RAMM Horse Fencing and Stalls

TABLE OF CONTENTS

ABOUT RAMM



- 2...Debbie's Letter to You!
- 3...Table of Contents
- 4...Contact & Shipping Info

FENCING



- 5...Fence Estimate Center
- 6...Planning Your Fence
- 7...High Impact Series Introduction
- 8...5" High Impact Performance
- 9...5" High Impact Performance Plus
- 10...4" High Impact Performance
- 11...High Impact Raceline Coated Wire
- 12...Life After Boarding
- 13...High Impact Components
- 14...High Impact Flex Fence Q & A
- 15...1" Pony Rail Flex-Fence
- 15...5.25" Horserail® Flex-Fence
- 15...4.25" Horserail® Flex-Fence 2-Wire
- 16...Fencing Components
- 17...Fencing Tools
- 18...Combination Fence
- 19...Extreme Farm Makeover
- 20...Electric Fence Q & A
- 21...1.5" Pro-Tek Electric Tape
- 22...Electrobraided™ Fence
- 23...Electrobraided™ Accessories
- 24...Hotcote® Electric Fence
- 24...Pro-Tek Electric Rope
- 25...1/2" Electric Tape Fence
- 25...1.5" Shock Tape Fence
- 25...Electric Twine Fence
- 25...Electric Polywire Fence
- 26...Portable Camping Corral
- 26...Protect Your Investment
- 27...Electric Fence Accessories
- 29...Electric Fence Chargers
- 30...Oak Board Fence
- 31...Wood Posts & Paint
- 32...PVC Fence
- 32...PVC Fence Accessories
- 33...Mesh Fence
- 34...Fence Gates & Latches
- 35...Round Pens

STALLS



- 36...Estimate Center
- 37...Pro-Line Stalls
- 38...Standard Stalls
- 40...Stall Accessories
- 41...Sliding Door Track Hardware
- 42...Stall Channeling
- 43...Welded Stalls
- 44...Custom Stalls
- 44...Custom Stall Partitions

EQUIPMENT



- 45...Interlocking Rubber Pavers
- 46...ThuroBed Mattress System™
- 47...Stall Mats
- 48...Waterers & Buckets
- 49...Feeders & Hay Racks
- 49...Tack Accessories
- 50...Classic Crafted Door Hardware
- 51...Horse Stocks
- 52...Track & Ring Conditioner
- 53...Arena Footing Treatment
- 54...Fly Control System
- 55...Arena & Stall Lighting
- 56...Run-In Sheds
- 58...Dutch & Bale Doors
- 59...Customer Testimonials

CONTACT US TODAY FOR YOUR FREE ESTIMATE!

Toll Free: 1-800-853-1611 – Fax: 419-825-2433 – Email: ramm@rammfence.com

RAMM Stalls & Horse Fencing



13150 Airport Highway
Swanton, OH 43558
Toll Free: 1-800-853-1611
Office: 419-825-2422
Fax: 419-825-2433
Email: ramm@rammfence.com
Website: www.rammfence.com

HOURS OF OPERATION

Monday - Friday
8:00 am - 6:00 pm
Saturday
9:00 am - 12:00 noon
(Eastern Standard Time)

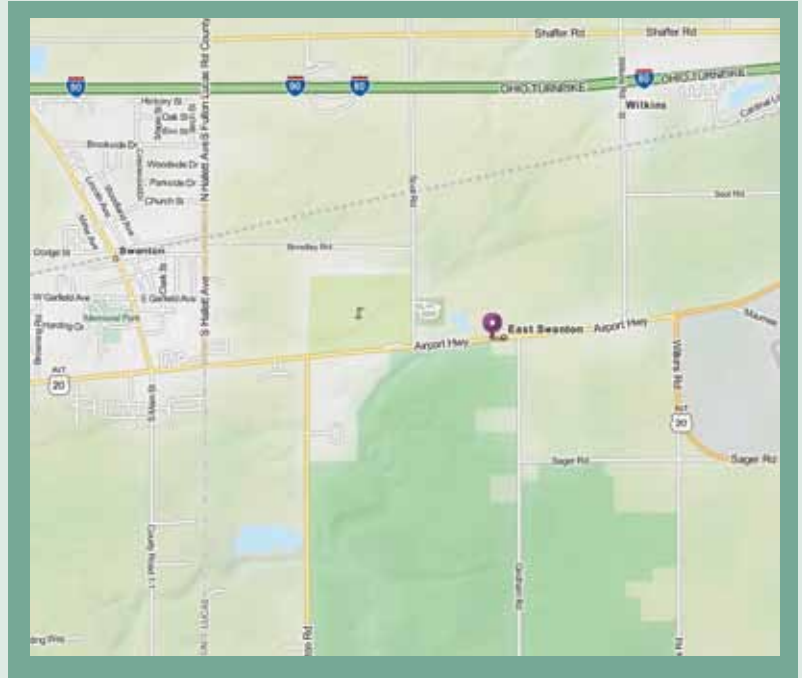

PAYMENT OPTIONS

All orders are to be paid in full prior to shipment. We accept Master Card, VISA, Discover, Money Wire Transfers and personal checks. Checks should be made payable to: RAMM Horse Fencing & Stalls.



RETURN POLICY

20% restock fee - IN STORE CREDIT ONLY. ALL returns must be made within 15 days.

HOW WE SHIP

Most orders under 70 lbs. are shipped UPS. Orders over 70 lbs. or oversized products are shipped common carrier freight. Customer is responsible for off-loading and signing for goods on arrival. Carefully check your order upon receipt, as damage sometimes occurs during shipping. All items are checked prior to shipment, and any damaged or missing packages must be noted with UPS or freight carrier at the time of delivery. Any shortages or inaccurate shipments must be reported to RAMM Horse Fencing & Stalls within 24 hours.

SHIPPING TIMES

1-99 rolls of fence-24 hours, 100 rolls and

higher-72 hours (in most cases). Please allow 4-6 weeks for custom stall orders.

UPS & FREIGHT DELIVERY

UPS & Freight rates are calculated by weight and/or weight per package. We can calculate shipping costs as soon as your total order is completed. UPS can leave packages at doorsteps without a signature, however, freight customers MUST be present to accept the order and off load it.



FLATBED

Some orders may need to ship via flatbed carrier instead of a common freight carrier. In this case, we will provide you with a flatbed delivery sheet that must be completed prior to delivery.

WARRANTY

The duration of our warranties are displayed on the page that the product appears. Most warranties are a limited manufacturer's warranty for the duration stated. Installation must comply with manufacturer's specifications for warranty claims to be valid. Instructions will accompany each product, and our representatives will be on hand to answer any questions regarding installation. Please contact RAMM Horse Fencing & Stalls for all warranty claims.

DISCLAIMER

RAMM Horse Fencing & Stalls, Inc. strives to ensure that all information in this catalog is correct and accurate, however the information in the catalog has been gathered from many sources. As a result, RAMM Horse Fencing & Stalls cannot be held responsible for misprints in pricing or typographical errors. Photographs in this catalog are from new and previous product lines. RAMM Horse Fencing & Stalls also disclaims responsibility for use or misuse of any products described in this sales guide, and any losses incurred through the use of any products according to the methods described herein. All products should be used according to the manufacturer's instructions. We have a constant product improvement plan in place and reserve the right to make changes and upgrades without notice. Prices subject to change without notice. This catalog supersedes all previous publications by RAMM Horse Fencing & Stalls.



FENCE ESTIMATE CENTER

FAX OR EMAIL YOUR LAYOUT FOR A **FREE** ESTIMATE!

In order to provide you with an accurate estimate, please sketch your layout (onto plain paper if you are faxing to us 419-825-2433) and answer the following questions. Include all of this information with the layout. If you need help, or are unsure of the best way to lay out your property, give us a call and we can help!

1. What type of fencing material are you interested in? How many rails (horizontal strands between the posts) do you need?
2. What do you need to accomplish with your fence? Keeping

horses away from a highway, cross fencing, riding arena, etc.?

3. Where will your gates be located and how many do you need? Placing them at corners can often cut down on cost.
4. What post spacing will be used? When fencing in horses, a maximum of 12' post spacing is best for most fencing. For high-traffic areas or smaller paddocks, 8' post spacing is better. What type of posts will you be using?
5. What are your soil conditions like? Rocks, sand, clay, hills, etc.?

6. Are there any special considerations or concerns, such as shared fence lines, trees, etc.? Tell us all you can and please be detailed so that we can help you get the best fencing for your farm.

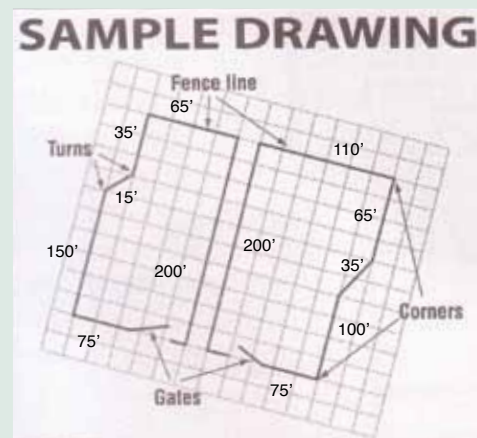

SQUARE ACREAGE GUIDE

1/4 acre	=	417'
1/2 acre	=	590'
3/4 acre	=	722'
1 acre	=	834'
2 acres	=	1182'
3 acres	=	1446'
4 acres	=	1670'
5 acres	=	1867'
6 acres	=	2046'
7 acres	=	2208'
8 acres	=	2361'
9 acres	=	2504'
10 acres	=	2640'
20 acres	=	3732'
50 acres	=	5900'

1/2 Mile or 160 Rods 160 ACRES Requires 2 miles or 640 rods of fence to enclose 1/2 Mile or 160 Rods	1/4 Mile or 80 Rods	40 Rods 20 Rods 20 Rods 20 Rods 20 Rods 20 ACRES	20 Rods 20 Rods 20 Rods 20 Rods Square 1-1/4 ACRES
	1/2 Mile or 160 Rods	1/4 Mile or 80 Rods 1/4 Mile or 80 Rods 1/4 Mile or 80 Rods 40 Rods Square 10 ACRES	1/4 Mile or 80 Rods 40 ACRES Requires 1 mile or 320 rods of fence to enclose 1/4 Mile or 80 Rods
1/2 Mile or 160 Rods	1/4 Mile or 80 Rods	1/4 Mile or 80 Rods	

CONTACT US TODAY FOR YOUR FREE ESTIMATE!

Toll Free: 1-800-853-1611 – Fax: 419-825-2433 – Email: ramm@rammfence.com

PLANNING YOUR FENCE

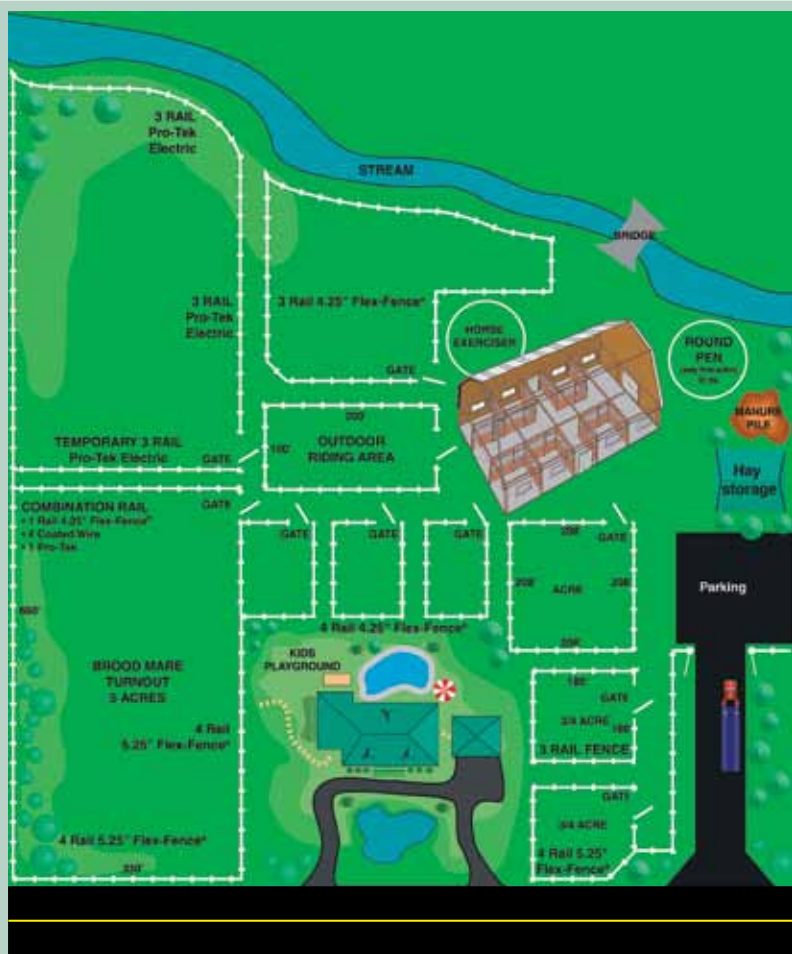

RAMM Horse Fencing - on the right road to quality!

SOME IMPORTANT QUESTIONS TO ASK WHEN PLANNING YOUR FENCE:

1. How large is your pasture? If you don't know, measure the distance between your existing posts and add the total footage. Or, measure the distance of one of your steps and walk off the area. If the area is open, drive stakes in the ground and string off the pasture.

2. How many horses will be in this area? Do you have Geldings, Mares, Foals, or Stallions?

3. Do you need to separate your horses? Do you need to do rotational grazing? Catch areas, pony or small animal containment as well as large horse pastures?

4. How many gates will you need? Include any that you are thinking about now, rather than adding them after installation is complete. Consider having a 16' "utility gate" at one end of your pasture for the use of large vehicles or equipment. Most turn-out gates should be 8, 10, or 12' in length. Our staff can give you suggestions for the size and placement.

5. What is the content of your soil? Do you have hills? Standing water? Sand or rock?

6. If you are considering electric do you have overhead electric lines or water lines close to where your fence will run?

7. Which areas will have the highest amount of congregating horses? This is considered a high traffic area. Do your horses test, chew, lean or otherwise

abuse fence? This is important to consider and discuss. We can give you ideas to help protect your fence and your investment of hard earned dollars!

8. What will you want to fence in the future? Our staff can help you save money if you plan ahead for future additions to your pastures.
9. Determine your budget; by doing this we can help you choose the right fence for your situation and budget. Remember: The difference between a good fence and a bad fence is usually one vet bill. Ask how we can help you with easy long-term maintenance. Our goal is to help you fence your horses safer and keep your fence looking new longer!
10. Most horses are in their pasture 50-100% of the time. A mature horse weighs between 1,200 to 1,800 pounds, and will contact your fence at some point. Make your pasture as safe as you can, choose a fence that is made for horses!
11. Can't do all you want at once? RAMM Horse Fencing & Stalls can help you determine your long-term farm and barn needs for your horses. You can break it down into phases and do your project in the time frame that works for you! It's better to know your goal, rather than "adding on". When you "add on" without a plan, your facility can become unorganized and lengthen the time it takes to do your every day chores.

NEW! HIGH IMPACT - INNOVATIVE FENCING



3 or 4 rail for your horse's particular needs



Grandmother installed this fence, herself!

"MOST REQUESTED FENCE" by our customers!

The innovative benefits of NEW High Impact provides THE EASIEST flex fence installation today. User-friendly installation video or manual provides step-by-step instructions so you get it right the first time! LIFETIME Limited Mfg. Warranty with our Plus Series is like no other flex fence on the market today! Over 10 years of research with in-house and farm testing! We selected the best polymer material coupled with the longest lasting - industry leading high tensile wire. We are the ONLY user of the double coated high tensile wire. "The ingredients in High Impact contain the maximum color and UV inhibitors that the polymer can absorb." Mildew resistant formula makes High Impact the future standard for horse farms, from Florida to Alaska!

Made proudly in the USA.

"Our installation video is of an actual farm fence that is installed by a woman in her 50's! We wanted to show how women can also install this fence, which should give many horse owners encouragement when it comes to putting up fence." Debbie Disbrow courtesy of *Equine Journal*, 'Innovations That Make Life Easier on the Farm' by Susan Winslow - Spring 2012



New High Impact easily flows around corners and follows the lay of your land.

CONTACT US TODAY FOR YOUR FREE ESTIMATE!

Toll Free: 1-800-853-1611 - Fax: 419-825-2433 - Email: ramm@rammfence.com

NEW!

RAMM Stalls & Horse Fencing

5" HIGH IMPACT PERFORMANCE



The greatest benefits of High Impact in a 5" rail, with economical pricing. 20 Year Limited Mfg. Warranty gives you years of better containment for your horses!

- 5" 3-wire Performance
- 4,200 lbs. minimum break strength per rail
- Double coated high tensile wire is mechanically trapped in our polyolefin plastic which is only offered by RAMM!
- Looks better than a board fence with no splintering or breaking problems
- Rail never needs to be painted
- Comes in either white, black or brown
- 20 Year Limited Mfg. Warranty
- **Made with pride in the USA**

WHITE, BLACK, BROWN	ITEM #	1-9 Rolls	10-29 Rolls	30+ Rolls
660' Roll - 5" High Impact Performance Roll only - Components sold separately	RA(W,B,BR)5660-124	\$366.36	\$359.48	CALL
330' Roll - 5" High Impact Performance Roll only - Components sold separately	RA(W,B,BR)5330-62	\$198.10	\$193.38	CALL

Freight F.O.B. Swanton, OH. Installation must comply with manufacturer's specifications. Prices subject to change without notice. Call for quantity pricing.

PRICE PER FOOT

1 RAIL ON YOUR POSTS	1 RAIL ON OUR POSTS
\$.78/ft	\$ 1.61/ft

3 RAILS ON YOUR POSTS	3 RAILS ON OUR POSTS
\$ 2.34/ft	\$ 3.17/ft

4 RAILS ON YOUR POSTS	4 RAILS ON OUR POSTS
\$ 3.12/ft	\$ 3.95/ft

All prices based on a 660' paddock with one gate opening at a corner and 12' post spacing. Price may vary depending on full-roll usage.
Accessories and freight are additional.

HIGH IMPACT COMPONENTS

- Diagonal Brace Plate
- Brace Pins
- Wire Links
- Ring Shank Nails
- End Plates
- End Tightener
- Post Brackets
- Splice Plate
- Bending Tool
- Wire cutters
- Ratchet Handle
- Lag Bolts
- Spinning Jenny
- Crimp Sleeves
- Crimp Tool

- See page 13 -



56 BRACKETS AND 112 RING SHANK NAILS
Used to attach 5" High Impact fencing to line posts. Brackets come in white, black or brown. Ring shank nails are 3.5 inches long.
Item #5NB(W,B,BR)K
Price: \$105.00 each



NEW!

RAMM Stalls & Horse Fencing

5" HIGH IMPACT PERFORMANCE PLUS



**Lifetime
Limited Mfg.
Warranty**

The widest rail in our High Impact PLUS series! 3 - 12.5 gauge double coated high tensile wires for superior strength. So easy to install, with revolutionary hardware, that a 55 year old grandmother can do it! The **ONLY** flex-fence that carries a **LIFETIME Limited Mfg. warranty.**

- 5" 3-wire Performance Plus
- 4,200 lbs. minimum break strength per rail
- Double coated high tensile wire is mechanically trapped in our polyolefin plastic which is only offered by RAMM!
- Looks better than a board fence with no splintering or breaking problems
- Rail never needs to be painted
- Comes in either white, black or brown
- Lifetime Limited Mfg. Warranty
- **Made with pride in the USA**

WHITE, BLACK, BROWN	ITEM #	1-9 Rolls	10-29 Rolls	30+ Rolls
660' Roll - 5" High Impact Performance Plus Roll only - Components sold separately	R(W,B,BR)5660-134	\$522.48	\$496.31	CALL
330' Roll - 5" High Impact Performance Plus Roll only - Components sold separately	R(W,B,BR)5330-67	\$279.23	\$265.28	CALL

Freight F.O.B. Swanton, OH. Installation must comply with manufacturer's specifications. Prices subject to change without notice. Call for quantity pricing.

PRICE PER FOOT

1 RAIL ON YOUR POSTS	1 RAIL ON OUR POSTS
\$1.02/ft	\$1.85/ft

3 RAILS ON YOUR POSTS	3 RAILS ON OUR POSTS
\$3.06/ft	\$3.89/ft

4 RAILS ON YOUR POSTS	4 RAILS ON OUR POSTS
\$4.08/ft	\$4.91/ft

All prices based on a 660' paddock with one gate opening at a corner and 12' post spacing. Price may vary depending on full-roll usage. **Accessories and freight are additional.**

HIGH IMPACT COMPONENTS

- Diagonal Brace Plate
- Brace Pins
- Wire Links
- Ring Shank Nails
- End Plates
- End Tightener
- Post Brackets
- Splice Plate
- Bending Tool
- Wire cutters
- Ratchet Handle
- Lag Bolts
- Spinning Jenny
- Crimp Sleeves
- Crimp Tool

- See page 13 -



56 BRACKETS AND 112 RING SHANK NAILS
Used to attach 5" High Impact fencing to line posts. Brackets come in white, black or brown. Ring shank nails are 3.5 inches long. Item #5NB(W,B,BR)K
Price: \$105.00 each



CONTACT US TODAY FOR YOUR FREE ESTIMATE!

Toll Free: 1-800-853-1611 – Fax: 419-825-2433 – Email: ramm@rammfence.com

NEW!

RAMM Stalls & Horse Fencing

4" HIGH IMPACT PERFORMANCE



High Impact Series can now offer you a 4" rail with 3 - 12.5 gauge double coated high tensile wires and a 20 Year Limited Mfg. Warranty at an economical price. Why pay more? Get a beautiful quality fence system that fits your budget today!

- 4" 3-wire Performance
- 4,200 lbs. minimum break strength per rail
- Double coated high tensile wire is mechanically trapped in our polyolefin plastic which is only offered by RAMM!
- Looks better than a board fence with no splintering or breaking problems
- Rail never needs to be painted
- Comes in either white, black or brown
- 20 Year Limited Mfg. Warranty
- **Made with pride in the USA**

WHITE, BLACK, BROWN	ITEM #	1-9 Rolls	10-29 Rolls	30+ Rolls
660' Roll - 4" High Impact Performance Roll only - Components sold separately	RA(W,B,BR)4660-107	\$338.00	\$331.24	CALL
330' Roll - 4" High Impact Performance Roll only - Components sold separately	RA(W,B,BR)4330-54	\$174.50	\$158.38	CALL

Freight F.O.B. Swanton, OH. Installation must comply with manufacturer's specifications. Prices subject to change without notice. Call for quantity pricing.

PRICE PER FOOT

1 RAIL ON YOUR POSTS	1 RAIL ON OUR POSTS
\$0.71/ft	\$1.54/ft

3 RAILS ON YOUR POSTS	3 RAILS ON OUR POSTS
\$2.13/ft	\$2.96/ft

4 RAILS ON YOUR POSTS	4 RAILS ON OUR POSTS
\$2.84/ft	\$3.67/ft

All prices based on a 660' paddock with one gate opening at a corner and 12' post spacing. Price may vary depending on full-roll usage. Accessories and freight are additional.

HIGH IMPACT COMPONENTS

- Diagonal Brace Plate
- Brace Pins
- Wire Links
- Ring Shank Nails
- End Plates
- End Tightener
- Post Brackets
- Splice Plate
- Bending Tool
- Wire cutters
- Ratchet Handle
- Lag Bolts
- Spinning Jenny
- Crimp Sleeves
- Crimp Tool

- See page 13 -



56 BRACKETS AND 112 RING SHANK NAILS
Used to attach 4" High Impact fencing to line posts. Brackets come in white, black or brown. Ring shank nails are 3.5 inches long.
Item #4NB(W,B,BR)K
Price: \$85.12 each



10

VISIT OUR WEBSITE FOR MORE DETAILS, SPECIALS, TRIVIA CONTEST, eNEWSLETTER and MORE!

www.rammfence.com

NEW!

RAMM Stalls & Horse Fencing

HIGH IMPACT RACELINE COATED WIRE



Our High Impact series would not be complete without a superior coated wire rail! Use alone or in any combination with your High Impact 5 or 4" rail.

- 5/16" diameter thick, coated high tensile wire
- 1,400 lbs. minimum break strength per rail
- Contains microbial agents and UV inhibitors to protect the rail from the elements
- Double coated high tensile wire is mechanically trapped in our polyolefin plastic which is only offered by RAMM!
- Looks better than a board fence with no splintering or breaking problems
- Comes in either white, black or brown
- 30 Year Limited Mfg. Warranty
- **Made with pride in the USA**

WHITE, BLACK, BROWN	ITEM #	1-9 Rolls	10-15 Rolls	16+ Rolls
1320' Roll - High Impact Raceline Coated Wire Roll only - Components sold separately	RC(W,B,BR)1320-70	\$159.98	\$158.38	CALL

Freight F.O.B. Swanton, OH. Installation must comply with manufacturer's specifications. Prices subject to change without notice. Call for quantity pricing.

PRICE PER FOOT

1 RAIL ON YOUR POSTS	1 RAIL ON OUR POSTS
\$0.13/ft	\$0.96/ft

3 RAILS ON YOUR POSTS	3 RAILS ON OUR POSTS
\$.39/ft	\$1.22/ft

4 RAILS ON YOUR POSTS	4 RAILS ON OUR POSTS
\$0.52/ft	\$1.35/ft

All prices based on a 660' paddock with one gate opening at a corner and 12' post spacing. Price may vary depending on full-roll usage.
Accessories and freight are additional.

HIGH IMPACT COMPONENTS

- Rail Fence Tensioner
 - In-line Tensioner
 - Tension Handle
 - Barbed Staple
 - Barbed Staple Driver
 - Spinning Jenny
 - Diagonal Brace Plate
 - Brace Pins
 - Wire Links
 - Ring Shank Nails
 - Wire cutters
 - Crimp Sleeves
 - Crimp Tool
- See page 13 -

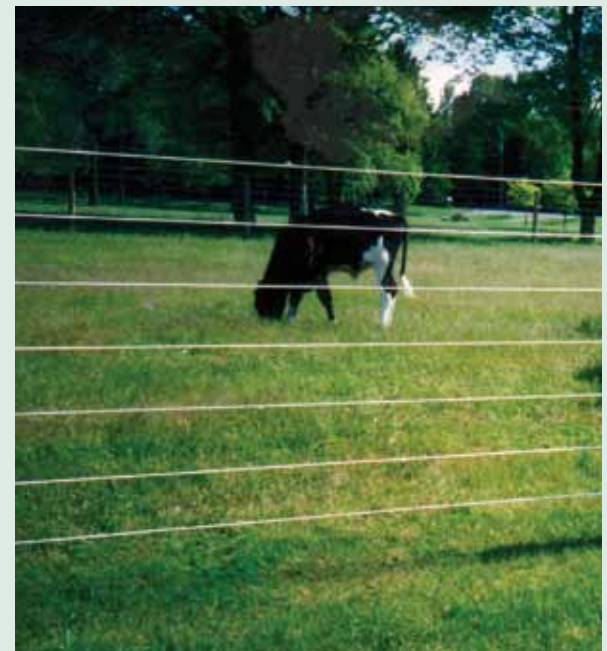

CONTACT US TODAY FOR YOUR FREE ESTIMATE!

Toll Free: 1-800-853-1611 – Fax: 419-825-2433 – Email: ramm@rammfence.com



LIFE AFTER BOARDING

BRINGING YOUR HORSE HOME

If you have always boarded your horses, the opportunity to bring them home is one of life's greatest pleasures. It is truly wonderful to be able to walk out of your home and visit with your equine friends any time you want.

Preparation of living quarters and pasture should be your first priority. Stable accommodations can be a simple outdoor shed or a complete barn, and pasture considerations are equally important. Deciding when, where, and for how long your horse is pastured is totally your choice. You'll also be the one to choose whether your horse will be pastured alone or with other horses.

As your horse's owner, you know his temperament best. If your horse is used to traveling, showing or trail riding, he may take the change completely in stride. But for many horses, a significant change in living arrangements can be pretty stressful. Your horse will need your love and reassurance

to make a smooth transition. Here are some tips that can make your horse's homecoming a little easier:

- Will you be feeding your horse the same feed he has become accustomed to in boarding? If not, purchase a limited quantity of his "board" fare so you can slowly introduce him to new feed. Mix hays and grains for a few days, gradually using less of the "board" feed and more of yours.
- Remember, not all water tastes the same to your horse. If the boarding facility's water source is different from home, the mineral content (iron, sulfur, etc.) may be substantially different and your horse may not drink. Bring some water home from the boarding facility and again, gradually mix the two until he has become accustomed to his "home" water.
- Is the trip home a lengthy one? Make travel as comfortable and easy as possible. Hay will help make for a more pleasant trailer ride. Make sure you plan for several watering stops along the way.
- You will be excited to get home with your horse, and so will he. Your horse will definitely pick up on your attitude, so focus on staying calm. This will help set the stage for an easier adjustment to a new environment.
- Whenever horses are introduced to a new pasture, it's a good idea to walk the fence line with them.



- Let him look, sniff and evaluate his new surroundings. If your horse is very excitable, you may want to start him out in his new stall with fresh water and hay. If possible, position him so that your horse has a "view" from his stall, so he can visually get used to his new surroundings.
- Always end on a positive note. Talk to your horse and praise good behavior. Keep him as calm as possible; turn out will be much easier. You may want to put hay out near the area where you will be retrieving him from turnout as a little extra "motivation."

Have a happy homecoming, and enjoy this next phase of horse ownership. Remember, there are many other preparations you need to make before bringing your horse home, and our staff is here to help you and your horse get off to a good start!



NEW!

RAMM Stalls & Horse Fencing

HIGH IMPACT COMPONENTS

High Impact's NEW hardware makes installation easier than ever! Simplified end plates and end tighteners allow a **one person install** (always follow manufacturing installation instructions). Fax, e-mail or call us with your layout and our fencing experts will calculate the hardware needed for your project. We are here for you and will answer any questions that you have!



END PLATE
Attaches High Impact Fencing to end posts. Comes in white, black or brown.
5" Item #5EPLATE (W,B,BR)-2
Price: \$ 14.88
4" Item #4EPLATE (W,B,BR)-2
Price: \$ 14.88



POST BRACKET
Attaches High Impact Fencing to line posts. Comes in white, black or brown.
5" Item #5NB(W,B,BR)-1
Price: \$ 1.68
4" Item #4NB(W,B,BR)-1
Price: \$ 1.28



SPLICE PLATE
Used to splice together two ends of High Impact fencing. Comes in white, black or brown.
5" Item #5SPLICE(W,B,BR)-2
Price: \$ 14.88
4" Item #4SPLICE(W,B,BR)-2
Price: \$ 14.88



END TIGHTENER
Used to tension High Impact Fencing. Comes in white, black or brown.
5" Item #5ETEN(W,B,BR)-4
Price: \$ 27.88
4" Item #4ETEN(W,B,BR)-4
Price: \$ 27.88

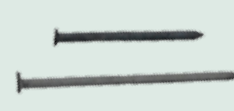

5" & 3.5" RING SHANK NAILS
Fastens tensioners to post. Tremendous holding power.
Item #5N
Price: \$3.98/lb. (21 nails/lb.)
Item #35N
Price: \$4.98/lb. (37 nails/lb.)



WIRE LINKS
Non-release, used to join or splice two ends of High Impact fencing. Rounded edges, horse friendly.
12.5 Gauge Item #WL
Price: \$2.98
16 Gauge Item #WL-16
Price: \$ 2.98



2" BARBED STAPLES
Used to terminate High Impact Flex Fence.
Item #BS2
Price: \$3.49/lb. (44 staples/lb)
Extra wide barbed staple to use with HotCote insulator tubing.
Item #BS2W
Price: \$3.98/lb



RAIL FENCE TENSIONER
Use to apply tension to fence. Use with RTH handle.
Item #TENSIONER-1
Includes 1 - 5" nail
Price: \$3.48



IN-LINE FENCE TENSIONER
Save time with the new quick end. Allows 12.5-gauge wire to be attached to the tensioner without connectors. Use with RTN handle.
Item #RTI-1
Price: \$4.95



END FENCE TENSIONER
Use to apply tension to fence. Use with RTN handle.
Item #RTE-1
Price: \$3.95



LAG BOLT
1/2" x 5" Hot Dipped Lag Bolt w/washer. Used to attach end and t-buckles at terminations.
Item #5LAGW-1
Price: \$1.49



NEW TENSIONER HANDLE
Use to apply tension to fence. Use with RTI or RTE tensioners.
Item #RTN-1
Price: \$4.95



TENSIONER HANDLE
Use with item code tensioner to tighten fence lines.
Item #RTH-2
Price: \$9.98



RATCHET HANDLES
Used with spoolers to tension fence rail. Handles 15" long.
Item #RH-4
Price: \$24.95



WIRE CUTTERS
Cuts high tensile wire.
Item #WC-2
Price: \$19.98



BARBED STAPLE DRIVER
Holds staples when driving them into posts.
Item #BSD-2
Price: \$12.98



BRACE PINS
Used for horizontal bracing systems.
5" Item #5BP-.05
Price: \$0.99
10" Item #10BP-.10
Price: \$1.29



CRIMP SLEEVES
12.5-gauge sleeves for all fences except 1" flex-fence. Requires Crimping Tool.
12.5-gauge - Item #CS125
Price: 30¢ ea., \$14.98/bag of 100



DIAGONAL BRACE PLATES
Supports diagonal post bracing at ends and corners. Includes 8 - 3.5" ring shank nails.
Extra heavy-duty.
Item #BRACEPLATE-1
Price: \$3.89

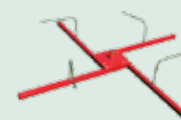

SPINNING JENNY
Put the stake in the ground and your wire on top. Walk the wire out the distance of your fence. For coated wire & 1" Flex-Fence. Comes with arm extensions.
Item #SJ-23
Price: \$59.00



CRIMP TOOL
Use when splicing rails together with crimp sleeves.
Item #CT-8
Price: \$65.00
Also available to rent. \$65 deposit required.

Freight F.O.B. Swanton, OH. Installation must comply with manufacturer's specifications. Prices subject to change without notice. Call for quantity pricing.

CONTACT US TODAY FOR YOUR FREE ESTIMATE!

Toll Free: 1-800-853-1611 - Fax: 419-825-2433 - Email: ramm@rammfence.com

HIGH IMPACT FLEX FENCE Q & A



**RAMM PRESIDENT,
DEBBIE DISBROW**
answers some of your
Flex Fence questions.

Q: What makes HIGH IMPACT Flex-Fence the best choice for my horses?

A: HIGH IMPACT Flex-Fence offers the key elements of strength and flexibility. Strength: this fence is one of the strongest available! When faced with an impact, it won't splinter like wood or PVC. Flexibility: this fence flexes on impact, and then returns to its original shape. Instead of staying rigid and possibly injuring your horse, this fence will give, while still keeping your horses confined. Flex-Fence combines the best of both worlds: stronger containment to help keep horses in their pastures, and the added safety of flexing on impact. The beautiful look is an added bonus!

Q: How is HIGH IMPACT Flex-Fence different from other flexible fences?

A: HIGH IMPACT PLUS Flex-Fence can only be found at RAMM, and our unique materials and manufacturing process makes this fence different right from the start! We use:

- 4,200 lbs. minimum break strength per rail
- Double coated high tensile wire is mechanically trapped in our polyolefin plastic which is only offered by RAMM!
- Looks better than a board fence with splintering or breaking problems
- Rail never needs to be painted
- Comes in either white, black or brown
- Lifetime Limited Mfg. Warranty
- **Made with pride in the USA**

Other flex rail products may look similar, but nothing can compare to the strength and durability of RAMM's HIGH IMPACT Flex-Fence!



Q: What are rails and how many do I need?

A: A rail is the horizontal piece of fence that attaches between posts. Most equine fencing consists of 3 or 4 rails. A 4-rail fence provides a better visual barrier, closer rail spacing and is more aesthetically pleasing. However, a 3-rail system will work for your horses if you plan on a shorter fence (approximately 4 feet). That way, spacing will be closer (rails should be no more than 9"-11" apart for horses). If you're on a budget and 3 or 4 rails aren't an option, ask our staff about combination fencing!

Q: Should rails go on the inside or outside of my posts?

A: Placing the rail on the inside of the post is recommended. Having the rail between the animal and post is stronger.

Q: What kind of posts do I need?

A: We recommend using pressure-treated pine posts. Round pine posts are strong, and also accept nails well. 6"x9' round, end and corner posts with 5"x8' line posts work with most rails and will provide a strong fence line. For smaller rails, 4"x8' line posts may be used.

RAMM Stalls & Horse Fencing

1" PONY RAIL FLEX-FENCE



Shown with 4.25", white, 2-wire top rail.

- 2 - 16 gauge pre-straightened galvanized wires
- 1,500 lbs. minimum break strength per rail
- Easier installation for you with the pre-straightened wires require less tension
- Versatile rail can be used alone, with existing fence system or as a combination fence system
- Great for horses, ponies and minis



WHITE, BLACK, BROWN	ITEM #	LIST PRICE	1-9 Rolls	10+ Rolls
660' Roll - 1" Flex Fence Roll only - Components sold separately	6601(W,B,BR)-70	\$178.00	\$159.75	CALL

5.25" HORSE RAIL® FLEX-FENCE



- 3-12.5 Gauge Pre-Straightened Galvanized Wires
- 4,860 lbs. minimum break strength per rail
- Save Time & Money with low maintenance fencing
- Easier Installation with revolutionary spooler system
- Designed specifically for horses!



WHITE, BLACK, BROWN	ITEM #	LIST PRICE	1-11 Rolls	12+ Rolls
660' - 5.25" Flex Fence Roll Roll only - Components sold separately	6605(W,B,BR)-190	\$598.00	\$455.25	CALL
330' - 5.25" Flex Fence Roll Roll only - Components sold separately	3305(W,B,BR)-95	\$308.00	\$247.63	CALL

4.25" HORSE RAIL® FLEX-FENCE 2-WIRE



- 2-12.5 Gauge Pre-Straightened Galvanized Wires
- 3,240 lbs. minimum break strength per rail
- Great visibility and affordable pricing
- Stands up to the toughest elements with UV protection
- Environmental friendly and recyclable



WHITE, BLACK, BROWN	ITEM #	LIST PRICE	1-11 Rolls	12+ Rolls
660' - 4.25" Flex Fence Roll Roll only - Components sold separately	66024(W,B,BR)-150	\$499.00	\$348.00	CALL
330' - 4.25" Flex Fence Roll Roll only - Components sold separately	33024(W,B,BR)-75	\$269.50	\$194.00	CALL

Freight F.O.B. Swanton, OH. Installation must comply with manufacturer's specifications. Prices subject to change without notice. Call for quantity pricing.

CONTACT US TODAY FOR YOUR FREE ESTIMATE!

Toll Free: 1-800-853-1611 - Fax: 419-825-2433 - Email: ramm@rammfence.com

RAMM Stalls & Horse Fencing

FENCING COMPONENTS

Proper hardware is imperative for your fence to be long lasting. From tightening your flex-fence to splicing your coated wire, we carry all the right components to do the job right the first time. RAMM has all the components that you will need to complete your fence project from tighteners, buckles, brackets, spoolers, and tensioners. We also carry a long line of fasteners and smaller items that are crucial in your fencing project, that you might overlook.



1" FLEX-FENCE STAPLES
Used with 1" Flex-Fence.
Item #PRS
Price: \$6.88/lb. (34 staples/lb.)



COATED WIRE TIGHTENER
Used to splice and tension coated wire.
Item #CWT-1
Price: \$7.95



COATED WIRE SLEEVE
Used to wrap coated wire around wood end posts.
Item #CWS- 0.5
Price: \$1.75



RAIL FENCE TENSIONER
Use to apply tension to fence.
Use with RTH handle.
Item #TENSIONER-1
Includes 1 - 5" nail
Price: \$3.48



IN-LINE FENCE TENSIONER
Save time with the new quick end. Allows 12.5-gauge wire to be attached to the tensioner without connectors. Use with RTN handle.
Item #RTI-1
Price: \$4.95



END FENCE TENSIONER
Use to apply tension to fence.
Use with RTN handle.
Item #RTE-1
Price: \$3.95



BRACKETS
5.25" Bracket
Item #5NB(W, B, BR)-1
Price: \$1.68
4.25" Bracket
Item #4NB(W, B, BR)-1
Price: \$1.28



END BUCKLE
5.25" End Buckle
Item #5EB(W, B, BR)-2
Price: \$9.98
4.25" End Buckle
Item #4EB(W, B, BR)-2
Price: \$8.98



SPLICE BUCKLE
Use to splice sections of flex-fence together.
5.25" Buckle
Item #5SB(W, B, BR)-2
Price: \$7.98
4.25" Buckle
Item #4SB(W, B, BR)-2
Price: \$6.98



T BUCKLE
5.25" T Buckle
Item #5TB (W, B, BR)-2
Price: \$10.75
4.25" T Buckle
Item #4TB (W, B, BR)-2
Price: \$8.98



FLEX FENCE SPOOLERS
5.25" Spooler
Item #5SPOOL(W,B,BR)2-2
Price: \$14.98
4.25" Spooler
Item #4SPOOL(W,B,BR)2-2
Price: \$12.98



45 DEGREE END BUCKLE
5.25" 45° End Buckle
Item #5EB(W, B, BR)45-2
Price: \$9.98
4.25" 45° End Buckle
Item #4EB(W, B, BR)45-2
Price: \$8.98



2" BARBED STAPLES
Used to terminate High Impact Flex Fence.
Item #BS2
Price: \$3.49/lb. (44 staples/lb.)
Extra wide barbed staple to use with HotCote insulator tubing.
Item #BS2W
Price: \$3.98/lb



BRACE PINS
Used for horizontal bracing systems.
5" Item #5BP-0.05
Price: \$0.99
10" Item #10BP-0.10
Price: \$1.29



5" & 3.5" RING SHANK NAILS
Fastens tensioners to post. Tremendous holding power.
Item #5N
Price: \$3.98/lb. (21 nails/lb.)
Item #35N
Price: \$4.98/lb. (37 nails/lb.)



LAG BOLT
1/2" x 5" Hot Dipped Lag Bolt w/washer. Used to attach end and t-buckles at terminations.
Item #5LAGW-1
Price: \$1.49



CRIMP SLEEVES
12.5-gauge sleeves for all fences except 1" flex-fence. 16 gauge sleeves are for 1" flex-fence. Requires Crimping Tool.
12.5-gauge - Item #CS125
Price: 30¢ ea., \$14.98/bag of 100
16-gauge - Item #CS16
Price: 30¢

ROUND CORNER BRACKET
Use this heavy duty, uniquely designed bracket for a 90° turn. Corner post can safely stay outside, away from horses and riders. Lag Bolts are not included with bracket.
Item #5RC(W, B, BR)-2
Price: \$5.45
Item #4RC(W, B, BR)-2
Price: \$4.95



WIRE VISE
Used to terminate lengths of 100' or less. Tensioning tool required, see page 19 for tool information.
5.25", 4.25" & coated wire - 12.5-gauge Wire Vise
Item #WV125-0.25
Price: \$2.98
1" Flex - 16 Gauge Wire Vise
Item #WV16-0.25
Price: \$2.98



WIRE LINKS
Used to join (splice) two ends of 1", Coated Wire, and Hot Cote. 12.5 Gauge Item #WL
Price: \$2.98
16 Gauge Item #WL-16
Price: \$ 2.98



DIAGONAL BRACE PLATES
Supports diagonal post bracing at ends and corners. Includes 8 - 3.5" ring shank nails.
Extra heavy-duty.
Item #BRACEPLATE-1
Price: \$3.89

Freight F.O.B. Swanton, OH. Installation must comply with manufacturer's specifications. Prices subject to change without notice. Call for quantity pricing.

FENCING TOOLS

The tools that you choose to use for your project will help to make the job **easier and faster**. RAMM carries a full line of tools for flex, electric, braid, tape, wire or PVC fencing. We suggest having a basic tool set so that when you do your periodic fence checks, you can make any necessary repairs immediately. Over time this is the best way to avoid any **unnecessary expenses from abuse or excessive wear**. You might even like to "ride" your way around your fence, as you check it! Get the benefit of time with your horse while you check out your fencing!

With coated wire fence, the spinning jenny is one of the most **useful tools you can use**. The roll of fence sits on the frame and unwinds as you walk your coated wire fence down the post line. Unwinding coated wire is necessary in order to not kink the wire - which can potentially weaken it. The spinning jenny is like an extra set of helping hands during your installation!

Ask our fencing experts what particular tools will help you with your project. We will be happy to explain their uses so you understand every step of your installation!



T-POST DRIVER
Weighted steel tube makes driving in a T-post easier & safer.
Item #TPD-25
Price: \$29.98



NEW TENSIONER HANDLE
Use to apply tension to fence.
Use with RTI or RTE tensioners.
Item #RTN-1
Price: \$4.95



TENSIONER HANDLE
Use with item code tensioner to tighten fence lines.
Item #RTH-2
Price: \$9.98



RATCHET HANDLES
Used with spoolers to tension fence rail. Handles 15" long.
Item #RH-4
Price: \$24.95



WIRE CUTTERS
Cuts high tensile wire.
Item #WC-2
Price: \$19.98



1" STAPLE DRIVER
Holds staples when driving 1" Flex-Fence staples into posts.
Item #SDJW-2
Price: \$18.98



10" FENCE PLIERS
Drives and pulls fence staples, also cuts wire.
Item #10FP-2
Price: \$14.98

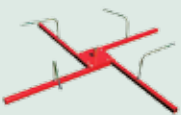

SPINNING JENNY
Put the stake in the ground and your wire on top. Walk the wire out the distance of your fence. For coated wire & 1" Flex-Fence. Comes with arm extensions.
Item #SJ-23
Price: \$59.00



BENDING TOOL
Used to easily and accurately shape the end of the rail to be inserted into either a joining or end buckle assembly.
Item #BT5-2
Price: \$14.25
Item #BT4-2
Price: \$13.75



CRIMP TOOL
Use when splicing rails together with crimp sleeves.
Item #CT-8
Price: \$65.00
Also available to rent. \$65 deposit required.



WIRE VISE TENSION TOOL
Use with wire vises to tighten fence lines, see page 18 for information on wire vises.
Item #TT-6
Price: \$37.98



BARBED STAPLE DRIVER
Holds staples when driving them into posts.
Item #BSD-2
Price: \$12.98

Freight F.O.B. Swanton, OH. Installation must comply with manufacturer's specifications. Prices subject to change without notice. Call for quantity pricing.

CONTACT US TODAY FOR YOUR FREE ESTIMATE!

Toll Free: 1-800-853-1611 - Fax: 419-825-2433 - Email: ramm@rammfence.com

COMBINATION FENCE

THE PROBLEM SOLVER FENCE SYSTEM

Do your horses need closer rail spacing? Do you need an extra barrier rail on the top and bottom of your fence? Or do you need an economical fence with strength and a clean look? Check out RAMM's combination fence! Any combination is right, if it fits your horses' needs.

Do you have an e-mail account? We can send you photos of our many customers' layouts to help you decide what will work for your horses. We can suggest ideas for stallion containment, "nursery paddocks," mini horses and so much more. Contact us today!

NURSERY PADDOCK

A nursery paddock grows with your horses. Contact us for more information!

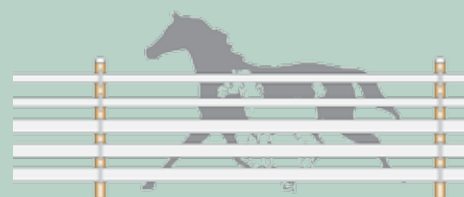

4.25" Flex with 1 strand of Hotcote®

This fence is highly visible with the flex fence and discourages horses from leaning on the fence with the electric coated wire at chest level.



4.25" Flex with 8 strands of Coated Wire

4.25" Flex used as top site rail while 8 strands of coated wire are great for a wide variety of horses, from foals to stallions.



5" Flex with 3 rails of electric tape

5" Flex is used as the top site rail with 3 rails of brown electric tape to discourage horses from sticking their heads through to the other side.



4.25" Flex with 3 rail Hotcote®, and 1 strand 1/2" Electric Tape

4.25" as a top site rail, electric fence in the middle combined with Hotcote® (electric rail at horses chest or leg height).



5.25" Flex with Mesh Wire Fence

This visible fence combination includes No-climb for predator control and to keep the mares and foals safe in their paddock. Also great for perimeter fencing.



4.25" Flex with 4 strands Hotcote®

Installed in the smaller handling areas, 1 Rail 4.25" with 4 strands of Hotcote® is visible, effective, and economical.

RAMM Stalls & Horse Fencing

EXTREME FARM MAKEOVER



Thunder Ranch and Training Center - Kathleen T. from Graham, WA

It has been a long journey... Eight years ago this coming June we bought a 5 acre ranch with a wreck of a barn that our three horses, at the time, didn't even want to be left in because it was so icky and spooky. That first day we moved to our little ranch and I put my horse in one of the stalls and she had a fit, nearly kicking down the rickety stall walls, I knew right then and there what our first project was going to be. So began our journey...

We gutted the barn with its nailed shut big front barn door. **It took three months to get the barn prepped in our spare time after work and on weekends.** In the meantime I was shopping for some kind of hardware, plans or kits to create the stall walls. During my search I found **the RAMM Fence Company.** The stall kits were well within our budget and I was thrilled to find I could modify the partition walls as Veronica, a **RAMM Sales Representative,** suggested with a grill window on the partition walls so the horses



Standard Stalls Fronts with V-Doors



Part Horse, Part Beaver



Behemoth horses - tall, strong and don't care what is in their way



Before - Old, chewed on board fencing



After - 5 1/2" Brown 3-wire Flex Fencing

could see each other.

The stall kits arrived and our journey continued... We saved money using the 2" X 6" boards from the hayloft to build the first three stall walls on the west side of the barn and only had to buy a few treated boards for the base of each wall and door. The stall walls and doors were **easy to assemble and looked beautiful** when completed and just in time for winter.

In the **spring of 2005** our journey took a turn... It didn't take long for us to find out that our horses are part beaver. I think Indians never dugout canoes... they just tied a horse next to a log. I called **RAMM Fence again for assistance.**

After receiving samples of the Flex Fencing and Electric Braid we decided to go with the Flex. I went with the brown 5 1/4" fence. **My husband and I installed all the Flex**

Fencing on the east side of the barn over one weekend (once the posts were in). Now we were able to play musical horses with our original three and an additional two ponies. We're up to five. We added **hot tape on top and bottom to avoid damage to the fence and gates because some behemoth horses know they are tall enough to reach the other side and strong enough not to care what's in their way.** Originally we used white hot tape from the feed store but have since changed it out with the brown tape

from RAMM which is more heavy duty for about the same price.

Our journey went west... Now it was time to tackle the west side of the barn. In 2006 we decided to start a **horse boarding and training facility** so we had to finish up the other stalls in the barn to make room for boarders.

The journey continues to this day as we have so many projects still to complete and many more fences to run. Our little Thunder Ranch and Training Center has come a long way from right before we moved in... until today.

Before - 2004



Currently - 2012



CONTACT US TODAY FOR YOUR FREE ESTIMATE!

Toll Free: 1-800-853-1611 - Fax: 419-825-2433 - Email: ramm@rammfence.com

ELECTRIC FENCE Q & A

HOW DOES ELECTRIC FENCE WORK?

This fence works by having an energy source that releases a pulse onto an insulated fence line about once every second. When an animal makes contact with the fence, the circuit is completed, and the animal receives a "shock." The current flows from the charger, down the fence line, to the animal, then finally to the ground.

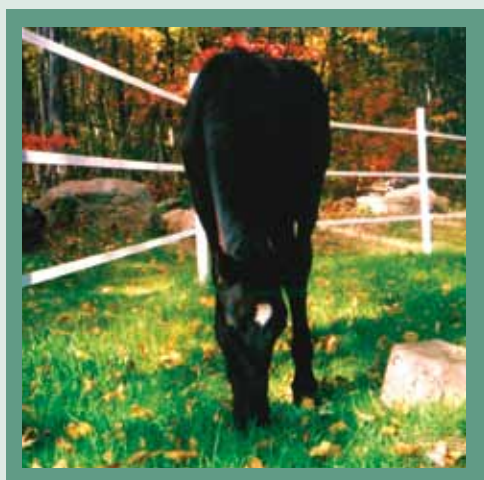

WHEN IS ELECTRIC FENCING NEEDED?

Does your horse lean, chew, crib, charge your fence or is overly active? Are your fences difficult to see? You will need electric fencing.

NUMBER OF STRANDS?

The number of strands of Electric Fence is a matter of your particular application. 65% of Electric Fence users install 3 strands. 4 strands are most commonly used when fencing along busy roads, around crowded areas, smaller paddocks, aggressive animals or foals. Always consider the rail or strand spacing most appropriate for your particular needs.

POSTS AND POST SPACING?

The type of post used is entirely

your choice. At RAMM we carry insulators for wood posts, PVC Sleeves, steel T-posts and Round Rods up to 5/8" in diameter. When using electric fencing for horses we recommend that your posts are spaced no further than 12-15 ft. All corner and end posts should be braced and concreted.

WHAT SIZE CHARGER DO I NEED?

A basic rule to follow is: 1 Joule = 6 miles of fence. That is only true in a perfect situation where you have perfect climate, no excess vegetation growth and no corrosion of wires. In most situations you should figure 1 joule for every 1-2 miles of fence.

WHAT ARE JOULES?

A joule is a measurement of electrical energy. 1 Joule is equal to 1 watt of power for 1 second of time (watt x time = joules)

WHAT IS THE DIFFERENCE BETWEEN LOW AND HIGH IMPEDANCE?

Low impedance fence chargers have the capability of increasing their energy output as the fence load increases. This means that if weeds touch the fence and draw voltage and



amperage to earth, a low impedance charger will begin to produce higher amounts of energy or joules. These higher energy levels will overcome the voltage and current loss caused by weeds and maintain energy levels on the fence for controlling animals. High impedance fence chargers do not have the capability of increasing their output energy as fence loads increase, and cannot overcome high levels of fence load. They "short out" when too many weeds touch the fence.

HOW MUCH SHOCK DO I NEED?

Experience has taught us that short-haired animals require a minimum of 2000 volts to control them: long-haired animals require approximately 3-4000 volts.

WHAT IS THE PRIMARY FUNCTION OF THE GROUNDING SYSTEM?

The grounding system is required to ensure maximum performance and stopping power. Remember that your shock is only as good as your grounding system and your ground rods complete your circuit. We recommend at least three ground rods, 5' long and spaced 10' apart.

1.5" PRO-TEK ELECTRIC TAPE

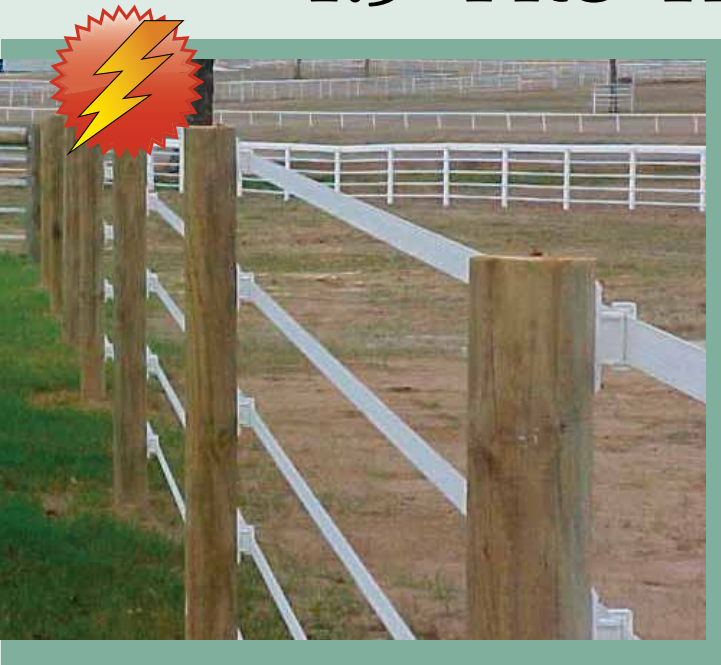

- 750 lbs. of break strength per rail
- Highly visible and available in white, black and brown
- Your horse will be safer - 15 stainless steel wires help keep your fence working properly, longer
- Affordable price, exceptional quality
- Can be used with wood or t-posts
- Easier installation - tensions by hand
- Stands up to the worst weather conditions - contains a UV guard
- Longer lasting, less maintenance - stainless steel conductive won't corrode
- **This is not your farm store fencing!**
- **For as low as \$0.13 per foot per rail**



WHITE, BLACK, BROWN	ITEM #	LIST PRICE	1-6 Rolls	7+ Rolls
1320' Roll - 1.5" ELECTRIC TAPE FENCE Roll only - Components sold separately	1320PT(W,B,BR)-20	\$199.00	\$169.00	\$158.40
660' Roll - 1.5" ELECTRIC TAPE FENCE Roll only - Components sold separately	660PT(W,B,BR)-10	\$97.00	\$87.00	\$84.00
330' Roll - 1.5" ELECTRIC TAPE FENCE Roll only - Components sold separately	330PT(W,B,BR)-8	\$51.00	\$47.50	\$44.50

Freight F.O.B. Swanton, OH. Installation must comply with manufacturer's specifications. Prices subject to change without notice. Call for quantity pricing.

PRICE PER FOOT

1 RAIL ON YOUR POSTS \$0.13/ft	1 RAIL ON OUR POSTS \$0.96/ft
---	--

3 RAILS ON YOUR POSTS \$0.39/ft	3 RAILS ON OUR POSTS \$1.22/ft
--	---

4 RAILS ON YOUR POSTS \$0.51/ft	4 RAILS ON OUR POSTS \$1.34/ft
--	---

All prices based on a 660' paddock with one gate opening at a corner and 12' post spacing. Price may vary depending on full-roll usage. **Accessories and freight are additional.**

ACCESSORIES

- Insulators, pg. 27
- Splicers pg. 27
- Tensioners pg. 27
- Charger, pg. 29
- Ground Rods, pg. 28
- Burial Wire, pg. 28
- Lightning Diverter, pg. 28
- Fence Tester, pg. 28
- Cutout Switch, pg. 28
- Posts, pg. 31
- Post Paint, pg. 31
- Gates & Latches, pg.34
- Electric Fence Sign, pg. 28
- Electric Gate Handle, pg. 27

CONTACT US TODAY FOR YOUR FREE ESTIMATE!

Toll Free: 1-800-853-1611 – Fax: 419-825-2433 – Email: ramm@rammfence.com

ELECTROBRAID™ FENCE



- The safe, secure, permanent electric fence
- ElectroBraid™ is lightweight and easier to handle allowing anyone to install it
- A double helix of copper wire conductors is braided into the outer jacket of the rope
- Outer braided jacket is made of very high grade polyester fiber - used in auto seat belts and parachute harnesses
- Resists attack by ultra-violet light, salt, manure and most farm chemicals
- Designed to minimize injuries and secure horses in a safer alternative

DESCRIPTION	ITEM #	WHITE	BLACK	SPECKLED
1000' Roll - ELECTROBRAID™ FENCE Roll only - Components sold separately	1000EB(W,B,S)-32	\$199.00	\$199.00	\$199.00
600' Roll - ELECTROBRAID™ FENCE Roll only - Components sold separately	EB(W,B,S)600-18	\$109.99	\$109.99	\$109.99

Freight F.O.B. Swanton, OH. Installation must comply with manufacturer's specifications. Prices subject to change without notice. Call for quantity pricing.

PRICE PER FOOT

1 RAIL
ON YOUR POSTS
\$0.20/ft

1 RAIL
ON OUR POSTS
\$1.05/ft

3 RAILS
ON YOUR POSTS
\$0.60/ft

3 RAILS
ON OUR POSTS
\$1.50/ft

4 RAILS
ON YOUR POSTS
\$0.80/ft

4 RAILS
ON OUR POSTS
\$1.75/ft

All prices based on a 660' paddock with one gate opening at a corner and 12' post spacing. Price may vary depending on full-roll usage. **Accessories and freight are additional.**

SEE PAGE
23 FOR ALL
ELECTROBRAID™
ACCESSORIES



ELECTROBRAID™ ACCESSORIES

INSULATORS



ELECTROBRAID™ ROLLER INSULATORS
Black/White. For corners, ends. Used with 2 1/2" Deck Screws. Item #EBR(I,IW)-1
Price: \$11.99/pkg. of 12



ELECTROBRAID™ LINE POST INSULATORS
Black/White. Item #EBLP(I,IW)-1
Price: \$5.10/pkg. of 25



ELECTROBRAID™ HEAVY DUTY LINE POST INSULATORS
For winter conditions. Item #ICC(W,B)-1
Price: \$8.98/pkg. of 25



T-POST TOPPERS
Black or White. To top a T-post and insulate the top strand. Not recommended for use with Hotcote®. Item #R4(W,B)-2
Price: \$8.98/pkg. of 10

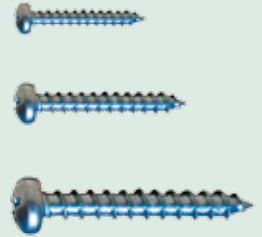

INSULATOR SCREWS
Stainless steel screws. For attaching insulators and tensioners to post. 1.5" Item #W16-1
Price: \$5.49 / 50 pk.
3/4" Item #I16-1
Price: \$4.98 / 50 pk.
1/2" Item #S16-1
Price: \$3.98 / 50 pk.



5" OFFSET INSULATORS
Black only with nails. For top board on existing fences. Item #EBOI-1
Price: \$3.99/pkg. of 10



2" OFFSET INSULATORS
Black only with nails. For top board on existing fences. Item #EB2OI-1
Price: \$3.59/pkg. of 25



LIGHTNING DIVERTER
Helps to protect fence chargers from lightning strikes. Item #LD-3
Price: \$12.98



T-POST LINE INSULATORS
White / Black. Item #TPIC(W,B)
Price: \$7.25/pkg. of 25

ACCESSORIES



ELECTROBRAID™ TENSION KIT
A required tool for tensioning the Braid™. complete with Braid™ Clamp, Ratchet, Rope and "S" Hook. Item #EBTKIT-4
Price: \$21.95



NEUTRAL PLATE CONNECTOR
Allows you to take power to or from an existing fence wire (not Braid™) fence using the copper lead-out wire. Item #EBNPC-1
Price: \$12.89



COPPER SPLIT BOLT CONNECTORS W. CABLE TIES
Used to splice and terminate Braid™ and for electrical connections. Item #EBCBOLT-1
Price: \$24.99/pkg. of 10



COPPER LEAD-OUT WIRE
200 feet. For wiring from your charger to the fence. Item #EB200-10
Price: \$84.99



ELECTROBRAID™ SPRING HANDLE GATE KIT
Includes 1 Roller Insulator, Webbing, 2 copper Split Bolts, 1 Gate Handle, 1 Activator Plate and SS Screws. Item #EBGATE-1
Price: \$18.99



DIGITAL VOLT METER-PW
Used to test your fence voltage. Item #DVM-1
Price: \$39.99



FENCE ALERT
Light will flash when voltage is low or erratic. 2 buttons. 2000 volt or below, second button - 2500 volt or below. Item #EFTSL-1
Price: \$19.98



ELECTROBRAID FENCE WARNING SIGN
Electric fences should be marked every 200-300 feet. Item #EBWARN-1
Price: \$5.99



COPPER CLAD GROUND ROD
6' tall. Includes Clamp, 2 Ferrules, 1 Cable Tie. Minimum three (3) Ground Rods recommended. Item #EBGR-7
Price: \$21.75



CUT-OFF SWITCH
Used to turn sections of fences on/off. Item #EBCOS-1
Price: \$9.70

CHARGERS

ZAREBA 50 MILE AC LOW IMPEDANCE CHARGER

115 volt main, 2 joules, pulsed output. Item #EB50
List: \$185.54
Price: \$154.28



ZAREBA 75 MILE AC LOW IMPEDANCE CHARGER

115 volt main, 4 joules, pulsed output. Item #EB75
List: \$222.00
Price: \$184.68



ZAREBA 100 MILE AC LOW IMPEDANCE CHARGER

115 volt main, 8 joules, pulsed output. Item #EB100
List: \$280.00
Price: \$222.50



ZAREBA 200 MILE AC LOW IMPEDANCE CHARGER

115 volt main, 16 joules, pulsed output. Item #EBZ100
List: \$528.80
Price: \$399.00



Freight F.O.B. Swanton, OH. Installation must comply with manufacturer's specifications. Prices subject to change without notice. Call for quantity pricing.

CONTACT US TODAY FOR YOUR FREE ESTIMATE!

Toll Free: 1-800-853-1611 – Fax: 419-825-2433 – Email: ramm@rammfence.com

RAMM Stalls & Horse Fencing

HOTCOTE® ELECTRIC FENCE



- 1,620 lbs. of break strength per rail
- 12.5 gauge pre-straightened high tensile steel wire
- Highly visible
- Great combination rail
- Polymer coating helps protect against injury
- Electric doubles the protection
- Cost effective
- **For as low as \$0.13 per foot per rail**
- See page 27 for accessories



WHITE, BLACK, BROWN	ITEM #	LIST PRICE	1-4 Rolls	5+ Rolls
1320' Roll - HOTCOTE® ELECTRIC FENCE Roll only - Components sold separately	1320HC(W,B,BR)-70	\$199.00	\$169.75	\$165.75

PRO-TEK ELECTRIC ROPE



- 350 lbs. of break strength per rail
- Longer lasting, better functioning stainless steel wires for great conductivity
- East to install with hand tension
- Economical
- Versatile great combination rail
- **For as low as \$0.07 per foot per rail**
- See page 27 for accessories



WHITE ONLY	ITEM #	LIST PRICE	1-6 Rolls	7+ Rolls
660' Roll - ELECTRIC ROPE FENCE Roll only - Components sold separately	660SR-12	\$49.98	\$44.98	\$39.98

Freight F.O.B. Swanton, OH. Installation must comply with manufacturer's specifications. Prices subject to change without notice. Call for quantity pricing.

RAMM Stalls & Horse Fencing



1/2" ELECTRIC TAPE FENCE



See page 27 for accessories

- Your horse will be safer - stainless steel wires help keep your fence working properly, longer
- Longer lasting, less maintenance - because we use stainless steel, which won't corrode
- Adds extra safety to existing fence systems
- **For as low as \$0.04 per foot per rail**

WHITE ONLY	ITEM #	OUR PRICE
1320' Roll - 1/2" ELECTRIC TAPE FENCE	1320EW-8	\$52.98
660' Roll - 1/2" ELECTRIC TAPE FENCE	660EW-4	\$26.98



1.5" SHOCK TAPE FENCE



See page 27 for accessories

- Improved visibility in all weather conditions
- 500 lbs. of break strength - per rail
- Color will not fade - UV protected
- Easy installation - tensioned by hand
- **For as low as \$0.11 per foot per rail**

WHITE ONLY	ITEM #	OUR PRICE
660' Roll - 1.5" ELECTRIC SHOCK TAPE	SLT660-11	\$69.98



ELECTRIC TWINE FENCE



See page 27 for accessories

- 220 lbs. of break strength - per rail
- Stainless steel wires with UV protected polyethylene
- Easy installation - tensioned by hand
- Great as a temporary fence or in combination with other rails
- **For as low as \$0.03 per foot per rail**

WHITE ONLY	ITEM #	OUR PRICE
1320' Roll - ELECTRIC TWINE	1320PTTW-4	\$39.98



ELECTRIC POLYWIRE FENCE



See page 27 for accessories

- Safer alternative to bare electric wire
- Easy installation - tensioned by hand
- Great for temporary fence or grazing management
- **For as low as \$0.03 per foot per rail**

WHITE ONLY	ITEM #	OUR PRICE
1320' Roll - ELECTRIC POLYWIRE	1320PW-8	\$35.98
660' Roll - ELECTRIC POLYWIRE	660PW-4	\$18.98

Freight F.O.B. Swanton, OH. Installation must comply with manufacturer's specifications. Prices subject to change without notice. Call for quantity pricing.

CONTACT US TODAY FOR YOUR FREE ESTIMATE!

Toll Free: 1-800-853-1611 - Fax: 419-825-2433 - Email: ramm@rammfence.com

PORTABLE CAMPING CORRAL



- Great for Trips on the Go!
- Perfect for horse shows, trail rides, hunting trips, etc.
- Complete kit—everything you need for a 200' corral inside a single, canvas bag
- Assembles in less than 15 minutes, with no tools!
- Durable, Lightweight - entire kit only 18 lbs.

KIT INCLUDES

- 8 two-piece posts
- 1 reel with 200' of electric fencing
- 8 round post insulators
- 5 tie-down cords and stakes
- 1 Horse Power Trail charger, battery operated (battery not included)
- 1 ground rod
- 1 canvas carry bag

PORTABLE CAMPING CORRAL

WHITE ONLY

ITEM #

OUR PRICE

200' PORTABLE CAMPING CORRAL

R60-18

\$270.48

Freight F.O.B. Swanton, OH. Installation must comply with manufacturer's specifications. Prices subject to change without notice. Call for quantity pricing.

PROTECT YOUR INVESTMENT

LIGHTNING PROTECTION IS ESSENTIAL TO PROTECTING YOUR INVESTMENT IN FENCE CHARGERS.

A good grounding system must be installed. A few feet of rod in the ground is not enough except for light portable chargers. If there are a lot of shorts on the fence and/or the ground is very dry, it is not uncommon to need more than 3 - 5' ground rods.

Ground rods should be ten feet apart and at least thirty feet from other existing grounds. Stay

away from water pipes (especially those going to drinking areas) or buildings where the electric charge may affect livestock (like milking areas) or people. The non-electrified wires on a fence can be connected to bring distant ground rods back to the ground terminal of the charger. Some installations have required over 10 - 8' ground rods.

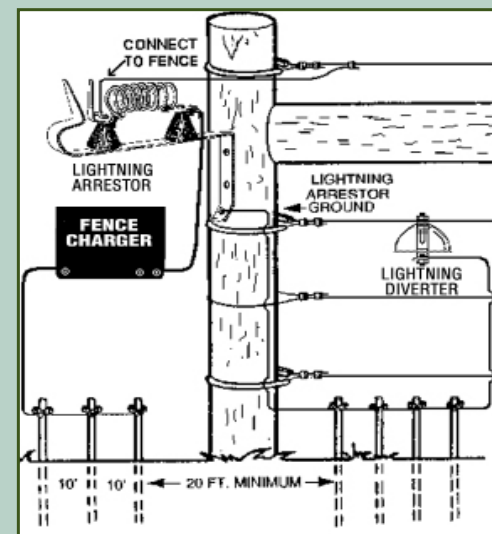

ELECTRIC FENCE ACCESSORIES

ELECTROBRAID™, ELECTRIC ROPE, HOTCOTE® & TWINE

 <p>RING INSULATOR Screws directly into wood post. For use with ring adapter. Item #IR(I,W)-0.5 Price: 59¢ ea. Blk. & Wht.</p>	 <p>T-POST CLAW INSULATOR Quickly clips to T-post. White and black available. Item #TPIC(W,B)-2 Price: \$7.25 / 25 pk.</p>	 <p>DOUBLE PIN LOCK INSULATOR Use on wood posts or plastic posts. (not for Hotcote use) Item #I81(W,B)-2 Price: \$8.98 / 25 pk.</p>	 <p>ROPE SPLICE Joins two ends of rope or braid, also used at terminations. Item #ES-0.5 Price: \$3.98 / pk. of 3</p>	 <p>CORNER/END TUBE INSULATOR WRAP Fits braid, rope, Hotcote, polywire and twine. 100' roll. Item #HCT(W,B,BR)-5 Price: \$16.98 / 100'</p>
 <p>CORNER/END STRAINER End and corner applications. Item #IE(S,SB)-0.5 Price: \$1.19</p>	 <p>T-POST PIN-LOCK INSULATOR Easy installation on T-post. (not for Hotcote® use)-2 Item #ITE Price: \$5.88 / 25 pk. Blk. only</p>	 <p>T-POST RING INSULATOR Slides over a standard T-post. Item #IRT-2 Price: \$9.98 / 25 pk. Blk. only</p>	 <p>WIRE TIGHTNER Allows for easy tightening of rope or braid. Item #WT-1 Price: \$2.98</p>	 <p>4" INSULATOR TUBE Insulates the fence line for braid, rope, Hotcote®, polywire or twine. Item #HC4T(W,B,BR)-1 Price: \$9.98 / 100 pk.</p>
 <p>U-BOLT CONNECTOR Joins two ends of rope or braid. Item #UBC-0.5 Price: \$1.39</p>	 <p>6" EXTENDED ANGLE RING INSULATOR Great for top electric fence rail. For use with ring adapter. Item #IWR6-2 Price: \$11.98 / 10 pk. Blk. only</p>	 <p>CLAW INSULATOR Heavy duty. Screws not included. Comes in white or black. Item #ICC(W,B)-2 Price: \$8.98 / 25 pk.</p>	 <p>RING INSULATOR ADAPTER Use with hand drill for quick easy installation. Item #DAIRI-2 Price: \$9.98</p>	<p>RAMM TIP Electric fence can be built as an inexpensive temporary fence or can be permanent. With our help, you can choose the materials that meet your requirements & budget.</p>

PRO-TEK ELECTRIC TAPE ACCESSORIES

 <p>3" EXTENDED T-POST INSULATOR Extends tape 3" from T-posts. White only. Item #EXTP25W-2 Price: \$11.98 / 25 pk.</p>	 <p>3" EXTENDED WOOD POST INSULATOR Extends tape 3" from wood posts. Nails included. White only. Item #EXWP25W-2 Price: \$11.98 / 25 pk.</p>	 <p>T-POST INSULATOR Use on steel T-line posts. Item #TP25(W,B)-0.5 Price: \$5.98 / 25 pk.</p>	 <p>END TENSIONER Begin and end each strand with this at gate posts or buildings. Item #R40(W,B)-0.5 Price: \$2.98</p>	 <p>SPLICE BUCKLE Stainless steel spring buckle similar to tensioner. Use to join rolls of webbing or repair torn webbing. Item #R24-0.5 Price: \$1.68</p>	 <p>GATE HANDLE Spring compresses for longer life. 1/2" or 1.5". (Buy 1 extra tensioner for handle end.) Item #R12(W,B)-1 Price: \$5.98</p>
 <p>UNIVERSAL INSULATOR Polyethylene insulator. For wood or plastic line posts. Lock face holds webbing tight. Item #R16(W,B)-2 Price: \$8.98 / 25 pk.</p>	 <p>ROUND ROD INSULATOR Use on fiberglass or steel round rod line posts. White only. Item #RP25W-2 Price: \$8.98 / 25 pk.</p>	 <p>CORNER TENSIONER For corners or any up or down hill direction change greater than 19°. Item #R50(W,B)-0.5 Price: \$3.98</p>	 <p>3-WAY TENSIONER Use at all cross fence junctions. Item #R55(W,B)-0.5 Price: \$4.98</p>	 <p>CONTACT CLAMP Connects charger to webbing when tensioner is inaccessible. Use R-58 wire to connect. Item #R9(W,B)-0.5 Price: \$3.98</p>	 <p>ELECTRIC TAPE GATE KIT 20 ft. of 1.5" tape, 2-R50 tensioners and 1-R12 spring gate handle. Item #R22(W,B)-2 Price: \$14.98</p>

Prices subject to change without notice.

CONTACT US TODAY FOR YOUR FREE ESTIMATE!

Toll Free: 1-800-853-1611 – Fax: 419-825-2433 – Email: ramm@rammfence.com

ELECTRIC FENCE ACCESSORIES

POST COMPONENTS



STEP IN PLASTIC POST
48" height with 8 insulators.
Accepts rope braid, tape,
polywire, and twine.
White Item #SIP48-1
Price: \$2.28
Black Item #BSIP48-1
Price: \$2.28



1/2" x 6' FIBERGLASS ROD
Works great with portable
and permanent fencing.
Item #R126
Price: \$4.72



2"x2"x5' POST SLEEVES
Covers for T-posts. 20 yr. warranty.
Cap is included.
White Item #TPSW-3
Price: \$6.98
Black Item #TPSB-3
Price: \$8.88



4"x4"x5' END & CORNER POST SLEEVES
Covers 4"x4" wood posts. 20 yr. warranty.
Item #EPS(W,B)-9
Price: \$19.98



T-POST CAP
A perfect cap for the top of a
T-post. Prevents horses from being
impaled. Not recommended for
use with hotcote. Wht. or Blk.
Item #R4(W,B)-2
Price: \$8.98 / 10 pk.

Freight F.O.B. Swanton, OH. Installation must comply with manufacturer's specifications. Prices subject to change without notice. Call for quantity pricing.

GENERAL ELECTRIC FENCE ACCESSORIES



INSULATOR SCREWS
Stainless steel screws. For attaching
insulators and tensioners to post.
1.5" Item #W16-1
Price: \$5.49 / 50 pk.
3/4" Item #116-1
Price: \$4.98 / 50 pk.
1/2" Item #S16-1
Price: \$3.98 / 50 pk.



ELECTRIC GATE HANDLE
Can be adjusted up to 20' with convenient
bungee cord. Needs additional R50 or ring
insulator to connect.
Item #ERG-2
Price: \$24.98

LED ELECTRIC FENCE TESTER

Five lights tell you the amount of voltage on
your fence line.
Item #R27-1
Price: \$14.98



HIGH VOLT BURIAL WIRE

10,000 volt under gate fence wire won't leak
voltage into ground. Bury 12" in conduit.
Recommended to run no farther than 50'
Item #R208-12 Price: \$49.98/200 ft.
Item #R108-12 Price: \$24.98/100 ft.
Item #R58-12 Price: \$12.98/50 ft.
S-BOLT Used to connect burial wire to fence
line.
Item #SBOLT **Price: \$2.78**



DOUBLE CUTOUT SWITCH
Used to disconnect power to one or more
areas of fencing..
Item #DTCSB-2
Price: \$12.98



SINGLE CUTOUT SWITCH
Use to disconnect power to a certain area of
your fence.
Item #STCSB-2
Price: \$11.98

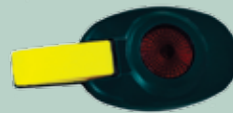

FENCE ALERT

Light will flash when voltage is low or erratic.
2 buttons. 2000 volt or below, second button
- 2500 volt or below.
Item #EFTSL-1
Price: \$19.98



GROUND ROD KIT

Includes 3 ground rods, 3 ground clamps, 50'
galvanized wire.
Item #GR3-16
Price: \$49.98
Single Ground Rod Kit with Clamp
Item #GR1-6 **Price: \$16.98**



LIGHTNING DIVERTER
Helps to protect fence chargers
from lightning strikes.
Item #LD-3
Price: \$12.98



LIGHTNING ARRESTOR
Made of plastic & is totally enclosed.
Can be mounted on hot fence with
split bolt or mounted to post.
Item #MWLA-3
Price: \$14.98



DIGITAL ELECTRIC FENCE COMPASS
Cordless voltage and current reading.
Item #DEFT-1
Price: \$119.00



REWIND REEL
Winds tape onto reel for easy
installation.
Item #RMINI-5
Price: \$34.29



ELECTRIC FENCE WARNING SIGN
Warns others of the presence of
electric fence.
Item #EFS-1
Price: \$5.99 / 3pk.

RAMM Stalls & Horse Fencing

ELECTRIC FENCE CHARGERS

EQUINE SERIES

This group is rated for cattle, horses, sheep, poultry, dogs and rabbits.



CORRAL

- Polytape -- 1-4 acres
- Coated Wire -- 8-12 miles
- Open Line Output - 6,100 V
- Output @500 Ohm - 3,300 V
- Stored Joules - 0.43

Item #HP40-2

Price: \$106.67 ea.



ACREAGE

- Polytape -- 6-10 acres
- Coated Wire -- 25-35 miles
- Open Line Output - 7,300 V
- Output @500 Ohm - 4,000 V
- Stored Joules - 1.20

Item #HP120-2

Price: \$127.62 ea.

PROFESSIONAL SERIES

This group is rated for cattle, horses, and sheep.



HERD BOSS

- Polytape -- 20-30 acres
- Coated Wire -- 50-70 miles
- Open Line Output - 8,300 V
- Output @500 Ohm - 5,000 V
- Stored Joules - 3.64

Item #HP300-7

Price: \$224.76



RANCHER

- Polytape -- 45-55 acres
- Coated Wire -- 120-130 miles
- Open Line Output - 9,500 V
- Output @500 Ohm - 6,200 V
- Stored Joules - 6.53

Item #HP600-7

Price: \$259.05



CATTLEMAN

- Polytape -- 70-90 acres
- Coated Wire -- 230-250 miles
- Open Line Output - 9,500 V
- Output @500 Ohm - 6,100 V
- Stored Joules - 12.53

Item #HP1200-10

Price: \$289.52

BATTERY OPERATION SERIES

This group is rated for horses, and sheep. Battery not included.



TRAIL

- Power Source - 2 D-cell, alkaline batteries
- Power Duration - approx. 8 weeks
- Polytape -- max 0.5 acres
- Coated Wire -- max 1 mile
- Open Line Output - 10,000 V
- Output @500 Ohm - 670 V
- Stored Joules - 0.024

Item #HPB2D-2

Price: \$100.95



NOMAD

- Power Source - 12 V DC external battery
- Power Duration - approx. 4 weeks
- Polytape -- 4-8 acres
- Coated Wire -- 20-30 miles
- Open Line Output - 8,500 V
- Output @500 Ohm - 3,800 V
- Stored Joules - 0.16

Item #HPB112-4

Price: \$213.33



PEGASUS

- Power Source - 4 internal D-cell, alkaline batteries or 12V DC external battery
- Power Duration - approx. 8-12 weeks
- Polytape -- 0.5-2 acres
- Coated Wire -- 2-5 miles
- Open Line Output - 6,400 V
- Output @500 Ohm - 750 V
- Stored Joules - 0.04

Item #HPB124-4

Price: \$188.57



PLAINSMAN

- Power Source - 12V DC external battery
- Power Duration - approx. 4 weeks
- Polytape -- 15-12 acres
- Coated Wire -- 45-55 miles
- Open Line Output - 9,600 V
- Output @500 Ohm - 4,950 V
- Stored Joules - 2.44

Item #HPB212-4

Price: \$236.19



SOLAR ADAPTOR

The HP-SK12V Solar Power Kit converts the Nomad and Plainsman into solar fence chargers. The powerful 11 watt solar panel is big enough to keep up with the high output of the Plainsman, insuring that the 12 volt battery is always charged even on rainy or cloudy days. It is fixed with an output regulator that prevents the battery from becoming over charged and back flow circuitry to prevent the battery power from draining back into the panel at night. The kit includes a post mounting bracket that holds the panel at a 45 degree angle on a wood or t-post.

Item #HPSK12V

Price: \$320.00

RAMM TIP

To determine what charger to use for 4 strands of electric fence - length x width = square footage. Square ft. divided by 43,560 = the # of acres. Acre listing is given for each charger.

Freight F.O.B. Swanton, OH. Installation must comply with manufacturer's specifications. Prices subject to change without notice. Call for quantity pricing.

CONTACT US TODAY FOR YOUR FREE ESTIMATE!

Toll Free: 1-800-853-1611 - Fax: 419-825-2433 - Email: ramm@rammfence.com

OAK BOARD FENCE



- TRUE CUT SIZE: 1" X 6" X 16'
- HIGH QUALITY ROUGH CUT OAK
- RAMM recommends the use of electric fence in high traffic areas
- ANY WOOD OR POSTS MUST BE DRY BEFORE PAINTING
- POSTS AVAILABLE - SEE PG. 31
- CONTACT US FOR LEAD TIMES, DUE TO HIGH DEMAND
- CALL FOR QUANTITY PRICING

ITEM	ITEM #	OUR PRICE
Oak Board 1" x 6" x 16'	NSOB	CALL

Freight F.O.B. Swanton, OH. Installation must comply with manufacturer's specifications. Prices subject to change without notice. Call for quantity pricing.



RAMM TIP

With horses, post spacing is recommended at 8, 10, or 12 feet. All board fence posts are set at 8 feet with 16 feet staggered rails.

WOOD POSTS



- PRESSURE TREATED RED PINE
- AVAILABLE FOR PICKUP
- SHIPPED IN LARGE QUANTITIES
- CCA TREATMENT
- TRUCKLOAD PRICING AVAILABLE

POST RECOMMENDED USAGE CHART

POST USAGE	4-5" x 8'	5" x 8'	6-7" x 9'
Line Posts	✓	✓	
Corner Posts			✓
Brace Posts	✓	✓	
Board Fence Posts		✓	

POST LIMITED WARRANTY: This product is warranted by the manufacturer against manufacturer's defects for the post only. Any additional charges incurred due to a warranty claim, including but not limited to, paint, concrete and labor for removal and installation are not covered. Please read the manufacturer's limited warranty for complete details.

ITEM	DIAMETER	LENGTH	ITEM #	OUR PRICE
Pressure Treated Posts	4", 5", 6"	8' or 9'	48P, 58P, 69P	CALL

Freight F.O.B. Swanton, OH. Installation must comply with manufacturer's specifications. Prices subject to change without notice. Call for quantity pricing.

PAINT



- WILL NOT FADE OR PEEL
- PAINTS APPROXIMATELY 50 POSTS PER BUCKET - LEAD FREE!
- RESISTS MILDEW AND CORROSION; LATEX - EASY WATER CLEANUP
- CAN BE SPRAYED OR BRUSHED ON POSTS OR BARNES
- PRODUCES A FLEXIBLE COATING IDEAL FOR BOARD FENCE

This paint is made especially for RAMM to ensure long life and high quality! Due to the nature of Fir wood, we do not recommend using RAMM paint. We suggest staining Fir, rather than painting it. Allow posts to dry 1-2 months if posts are wet. If painting black, allow 3 months if posts are wet.

5 GALLONS	ITEM #	OUR PRICE
WHITE	FCW-55	\$88.00
BLACK	FPB-55	\$68.00
BROWN	FCBR-48	\$68.00

Freight F.O.B. Swanton, OH. Installation must comply with manufacturer's specifications. Prices are subject to change without notice.

CONTACT US TODAY FOR YOUR FREE ESTIMATE!

Toll Free: 1-800-853-1611 – Fax: 419-825-2433 – Email: ramm@rammfence.com

PVC FENCE



- **LIFETIME LIMITED WARRANTY**
- **CUSTOMIZED** with your choice of caps
- **BEAUTIFUL, STATELY LOOK**
- **LOW-MAINTENANCE**
- **GREAT FOR DRIVEWAYS, ARENAS, DECORATIVE FENCE**
- **NO DISCOLORATION OR FADING**
UV stabilized

RAMM TIP

We **HIGHLY** recommend the use of electric fencing in conjunction with PVC when containing livestock



ITEM	RAILS	OUR PRICE
PVC Fence	2, 3, & 4 Rail Styles	CALL

Freight F.O.B. Swanton, OH. Installation must comply with manufacturer's specifications. Prices are subject to change without notice. Call for quantity pricing.

PVC FENCE ACCESSORIES



PVC NOTCHING TOOL

Used to notch blank rails to keep them in place. Available for purchase or to rent.

Item #NOT-10

Price: **CALL**



PVC POST STIFFENER

Aluminum I-beam used to strengthen a PVC post to carry the weight and strain of a gate.

7' Post Stiffener

Item #PR7-10

Price: **CALL**

8' Post Stiffener

Item #PR9-10

Price: **CALL**



PVC GATE DROP KIT

Place on the outside bottom edge of a PVC gate to secure an open or closed position.

Item #DRK-6

Price: **CALL**



PVC GATE KIT

Matches PVC fence. Available in 2, 3, and 4-rail styles, with or without rails.

Price: **CALL**

MESH FENCE



HORSEMAN MESH

- GREAT RUST PROTECTION—2.5 times the zinc coating of traditional hinge joint fencing
- 12.5 and 10 gauge galvanized high-tensile wires - Class 3
- Closely spaced woven design prevents horses from stepping through fence
- Special knot design helps prevent damage to your horse's skin, while making the fence more rigid

ITEM	HEIGHT	LENGTH	OUR PRICE
Horseman Mesh	48", 60", 72"	100', 200'	CALL



NON-CLIMB MESH

- Closely-woven pattern helps prevent animals from "walking down" the fence
- Knot structure prevents buckling and sagging - Class 1
- Great rust protection - made from 12.5 and 10-gauge galvanized wire
- Ask about our exotic animal fences for deer, elk, llamas, camel, kangaroos and ratite.

ITEM	HEIGHT	LENGTH	OUR PRICE
Non-Climb Mesh	48", 60", 72"	100', 200'	CALL



DIAMOND MESH

- Close spacing helps keep predators out
- Know construction prevents horse's hooves and legs from becoming caught in the fence - Class 1, but available in Class 3
- 2 wires on 4" spacing from ground up

ITEM	HEIGHT	LENGTH	OUR PRICE
Diamond Mesh	50", 58"	165'	CALL



V-MESH

- Helps keep predators out!
- Close spacing prevents hooves and legs from getting caught in the fence
- Safer, stronger construction - made from 12.5 and 14 gauge galvanized high tensile wires - Class 1
- Features 2 heavy twisted horizontal cables and vertical wires securely wrapped around each horizontal cable

ITEM	HEIGHT	LENGTH	OUR PRICE
V-Mesh	50", 58"	165'	CALL

Freight F.O.B. Swanton, OH. Installation must comply with manufacturer's specifications. Prices subject to change without notice. Call for quantity pricing.

CONTACT US TODAY FOR YOUR FREE ESTIMATE!

Toll Free: 1-800-853-1611 – Fax: 419-825-2433 – Email: ramm@rammfence.com

FENCE GATES

2" GALVANIZED GATE

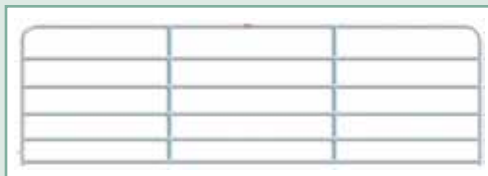

- 2" 16 Gauge heavy duty steel tubing
- 6 rails, 50" High
- Galvanized finish is ideal for warm, humid climates and coastal areas
- Takes rugged abuse from animals and elements
- Horizontal tubes are notched and welded for additional strength

2" HOT-DIPPED GALVANIZED GATE

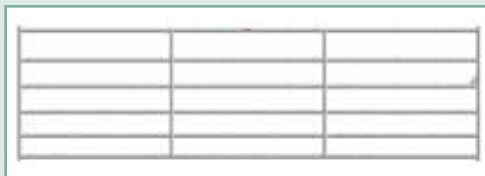

- 2" 16 Gauge heavy duty steel tubing
- 6 rails, 50" High
- Extra heavy 11-gauge vertical brace
- Square corners for increased animal safety
- The ultimate in tough and durable
- Completely dipped after fabrication for total coverage

2" POWDER-COAT PAINTED GATE

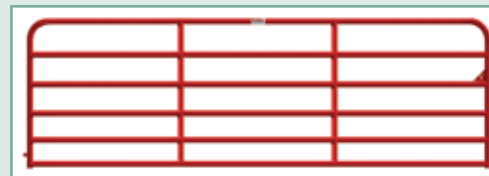

- 2" 16 Gauge heavy duty steel tubing
- 6 rails, 50" High
- Long-lasting, UV resistant powder coat finish
- Horizontal tubes are notched and welded for additional strength
- Vertical Z-braces offer extra strength and support

LENGTH	ITEM #	OUR PRICE
6' Gate	62GTG-62	\$140.00
10' Gate	102GTG-97	\$178.00
12' Gate	122GTG-113	\$201.00
16' Gate	162GTG-147	\$245.50

LENGTH	ITEM #	OUR PRICE
6' Gate	62GTGS-63	\$156.00
10' Gate	102GTGS-103	\$207.00
12' Gate	122GTGS-118	\$233.00
16' Gate	162GTGS-156	\$286.50

LENGTH	ITEM #	OUR PRICE
6' Gate	62BTG-58	\$110.50
10' Gate	102BTG-97	\$148.00
12' Gate	122BTG-113	\$167.50
16' Gate	162BTG-151	\$204.50

GATE LATCHES & ACCESSORIES



2-WAY LOCKING LATCH

- Fits gates with 1 5/8" - 2" O.D. round tube
- Latch releases so gate can swing either direction
- One handed operation
- Prevents gate from sagging or swinging
- Can be opened from horseback

Item #2175-5
Price: \$19.98



1-WAY LOCKING LATCH

- Fits gates with 1 5/8" - 2" O.D. round tube
- Prevents gate from sagging
- Can be opened from horseback

Item #2177-5
Price: \$16.98



GATE LATCH BOLT KIT

(4 lag bolts)
Item #4BK-.5
Price: \$2.98

QUICK CHAIN LATCH

Galvanized latch, opens with ease on horseback or off with one hand. Comes with 14" chain.

Item #KLG-2
Price: \$7.98



GATE ANCHOR

- Holds gate in any open position.
- Prevents sagging/swinging
- May also be used horizontally as a slide latch
- Anchor pins

Item #2178-5
Price: \$16.98



GATE WHEEL

- Fits ALL gates with round tubing from 1 5/8" to 2" diameter
- Prevents gate end from sagging and gouging ground
- Will open and close with ease
- Ground must be level

Item #GW-5
Price: \$16.98

2" GATE HINGE HARDWARE KIT

Bolt goes through the post completely and bolts on the other side.

Item #2180-6
Price: \$24.98



Freight F.O.B. Swanton, OH. Installation must comply with manufacturer's specifications. Prices subject to change without notice. Call for quantity pricing.

PRO-TEK ROUND PENS



A round pen is a great investment, no matter how many horses you have. This useful tool provides an isolated environment for one-on-one work. It's often a safer way to work with young horses, excitable horses, or horses that are rehabilitating from an injury. When not in use, your round pen can be made into a temporary stall!

These round pen panels are designed for use in the round pen system, and are not intended to be used as fencing or gates. They should not be used with horses for other purposes.

PRO-TEK ROUND PEN

LIGHT DUTY

- Welded construction from 19 gauge 1-11/16" diameter steel tubing
- Pre-Galvanized for outdoor weathering
- Center Support for bar strength
- Panels are 6' tall
- Gate panel is 8'8" t x 6' w
- Actual gate is 4.5' t x 5.5' w
- Gate swings in both directions
- Squared Welded Legs (17.25" 90° corner)

DESCRIPTION	ITEM #	OUR PRICE
50' LD System, 1 gate	PTL50-1075	\$1998.00
60' LD System, 1 gate	PTL60-1200	\$2250.00

PRO-TEK ROUND PEN

HOT-DIPPED GALVANIZED

- Welded construction from 14 gauge 1-7/8" diameter steel tubing
- Hot-dipped Galvanized
- Center Support for bar strength
- Panels are 6' tall
- Gate panel is 8'8" t x 6' w
- Actual gate is 4.5' t x 5.5' w
- Extra strength with bent tubing, not welded
- Rounded Legs (16" rounded corner)

DESCRIPTION	ITEM #	OUR PRICE
50' HD System, 1 gate	PT50-1300	\$3750.00
60' HD System, 1 gate	PT60-1600	\$4250.00

Freight F.O.B. Swanton, OH. Installation must comply with manufacturer's specifications. Prices subject to change without notice. Call for quantity pricing.

CONTACT US TODAY FOR YOUR FREE ESTIMATE!

Toll Free: 1-800-853-1611 – Fax: 419-825-2433 – Email: ramm@rammfence.com

ESTIMATE CENTER

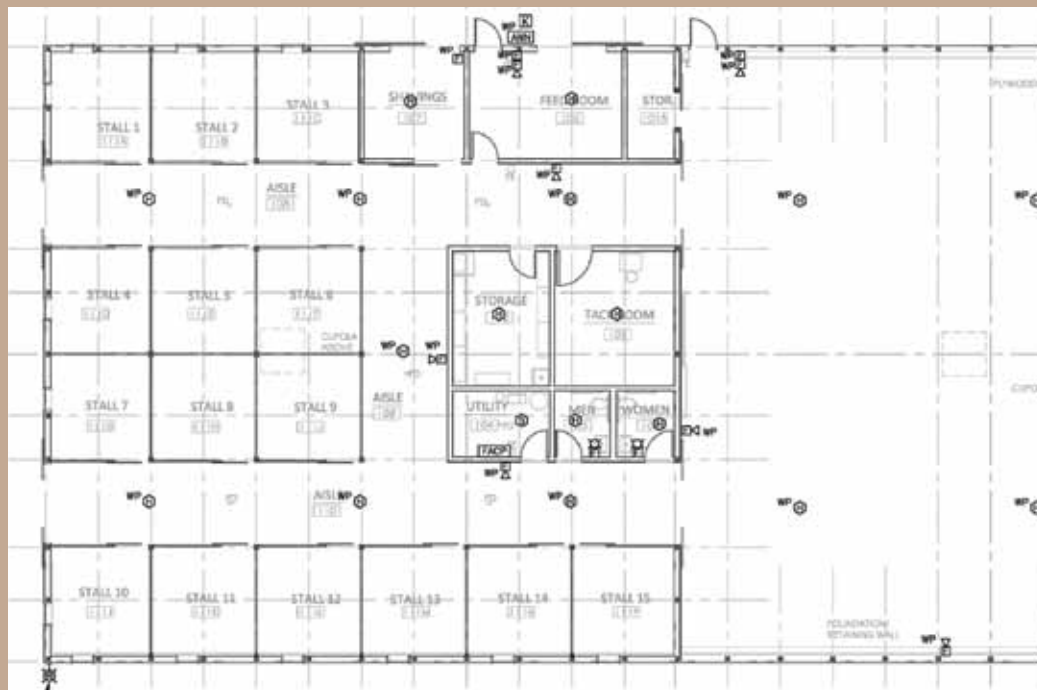

Fax or e-mail your layout for a FREE estimate!

In order to provide you with an accurate estimate, please sketch your layout and answer the following questions. Be as accurate as you can. Any additional information you have will help us help you! If you are unsure of the best way to lay out your barn and stalls, give us a call and we can give you time proven ideas!

Give us as much detail as possible, including dimensions of stalls, aisleways, windows that need grills, etc.

• **Which stall systems are you interested in?**

Remember, if you don't have support posts in your barn, you will either need to add them or use the Finish-Line, Portable/ Panel or Racetrack system.

• **What do you need to accomplish with your stalls?**

Foaling, stalling stallions, sale barn, boarding, etc.?

• **Where will your tack storage and wash rack be located?**

Depending on your layout, we may be able to save you money by strategically positioning your stalls.

• **What dimensions will your stalls be?**

Take into account the size of your horse, and remember that the bigger your stall, the better it is for your horse.

• **Will you need solid partitions or solid back walls?**

These are the most over looked areas that take a lot of abuse. Grilled partitions increase ventilation and encourage socialization. Think about which horses will be stalled next to each other and whether they get along.

• **What is your climate like?**

Could your barn be open all year long, or would harsh winters and heavy winds make it necessary to shut it up tight?

• **Do you need to plan for feed openings or feed doors large enough to hold a hay and grain feeder?**

Do you want wall feeders, corner grain feeders? Bucket doors?

• **Do you want right or left hand doors?**

Some stall fronts are available with doors that open to the right or the left. After seeing your layout, we can make a recommendation on which way your doors should open.

• **Do you have any special considerations or concerns with your barn?**

Tell us all you can so we can help you get the best stall system for your horses.

RAMM Stalls & Horse Fencing

PRO-LINE STALLS

The Pro-Line horse stall systems offer superior quality at an economical price. This horse stall system makes it easy for those on a budget to find everything they need to build attractive, functional stalls for their horses. These stall fronts attach to the front of your support posts. The latch on this stall is a quick and easy slide latch system. Square track rollers provide an even and quiet stall door opening and closing. Non-corrosive galvanized steel will ensure that your horse stalls stay looking beautiful for years to come.



STEP 1: Select your stall front

STEP 2: Select your door

STEP 3: Select the hardware

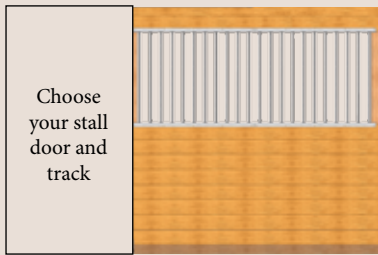

10 ft. Stall Front with grill work
Item #1110
List: \$124.00
Price: \$98.00

12 ft.
Item #1112
List: \$149.00
Price: \$119.00



PRO-LINE GRILL TOP DOOR
Smooth sliding door with grill top for added ventilation.

Galvanized Door
Item #PLA
List: \$169.00
Price: \$129.00

PRO-LINE DOOR HARDWARE KIT
Includes everything you need to connect your sliding grill top door to your stall front. Also includes 8 ft. long square track.

Galvanized
Item #1100
List: \$149.00
Price: \$118.00



24" PRO-LINE GRILL SECTION
Easily assembled kit for stalls, doors, ect. Includes Channeling, bars and grommets. Screws sold separately.

Galvanized
Item #24GWPL
List: \$49.00
Price: \$39.00

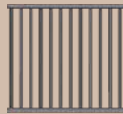

48" PRO-LINE GRILL SECTION
Easily assembled kit for stalls, doors, ect. Includes Channeling, bars and grommets. Screws sold separately.

Galvanized
Item #48GWPL
List: \$74.00
Price: \$59.00

PRO-LINE GRILLED PARTITION



10 ft. Grilled Partition
Item #PL10GP-110
List: \$189.00
Price: \$157.00

12 ft. Grilled Partition
Item #PL12GP-135
List: \$219.00
Price: \$177.00

PRO-LINE SOLID PARTITION

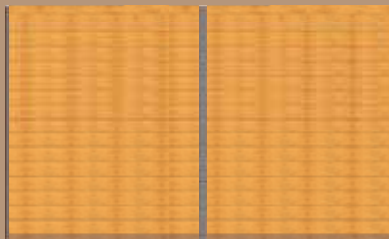

10 ft. Solid Partition
Item #SKSP-35
List: \$109.00
Price: \$88.00

12 ft. Solid Partition
Item #SKSP-35
List: \$109.00
Price: \$88.00

PRO-LINE PRIVACY GRILL PARTITION

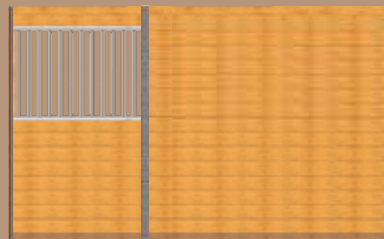

10 ft. Privacy Partition
Item #1148
List: \$248.00
Price: \$199.00

12 ft. Privacy Partition
Item #1148
List: \$248.00
Price: \$199.00

Wood not included on all stall systems. All prices subject to change without notice. Call for quantity pricing.

CONTACT US TODAY FOR YOUR FREE ESTIMATE!

Toll Free: 1-800-853-1611 – Fax: 419-825-2433 – Email: ramm@rammfence.com

RAMM Stalls & Horse Fencing

STANDARD STALLS

Our heavy-duty grommets are larger than others, covering the entire opening and overlapping to help eliminate rattling with your bars. The Standard Stall system allows you to replace single bars, instead of the entire grill! We pay attention to the smallest details, so you get high quality products. Standard Stalls feature 2 3/8" spacing between bars (3 1/4" on the center).



STEP 1: Select your stall front

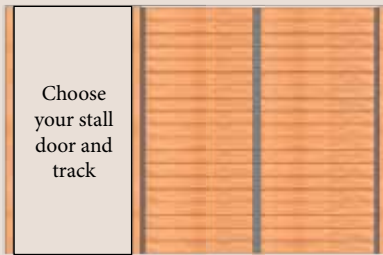

10 ft. Stall front with solid wall
Item #SKSP-35
List: \$109.00
Price: \$88.00

12 ft.
Item #SKSP-35
List: \$109.00
Price: \$88.00



10 ft. Stall front with feed opening
Item #1214
List: \$210.00
Price: \$174.00

12 ft.
Item #1216
List: \$245.00
Price: \$205.00

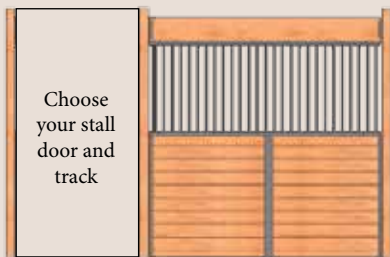

10 ft. Stall front with grill work
Item #1210
List: \$184.00
Price: \$148.00

12 ft.
Item #1212
List: \$219.00
Price: \$179.00

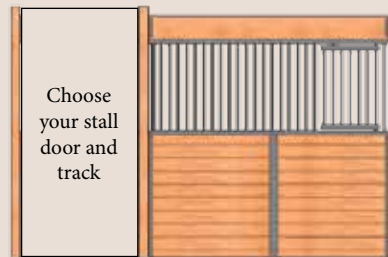

10 ft. Stall front with feed door
Item #1211
List: \$393.00
Price: \$317.00

12 ft.
Item #1215
List: \$428.00
Price: \$348.00

STANDARD SOLID PARTITION



10 ft. Solid Partition
Item #SKSP-35
List: \$109.00
Price: \$88.00

12 ft. Solid Partition
Item #SKSP-35
List: \$109.00
Price: \$88.00

STANDARD PRIVACY GRILL PARTITION



10 ft. Privacy Grill Partition
Item #1248
List: \$273.00
Price: \$219.00

12 ft. Privacy Grill Partition
Item #1248
List: \$273.00
Price: \$219.00

Wood not included on all stall systems. Wall brace shown comes with 12' size only. All prices subject to change without notice. Call for quantity pricing.

RAMM Stalls & Horse Fencing

STEP 2: Select your door



SOLID DOOR
Allows private stalling of your horses for greater peace of mind. Great for constantly rotating horses in and out of your barn.

Galvanized Door
Item #SSL
List: \$188.00
Price: \$148.00

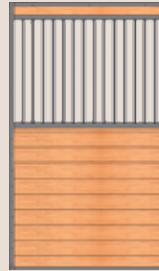

GRILL TOP DOOR
Smooth sliding door with grill top for added ventilation.

Galvanized Door
Item #SSA
List: \$248.00
Price: \$199.00

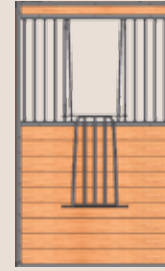

GRILL TOP V-DOOR
V-door that allows your horse freedom to socialize with other horses.

Galvanized Door
Item #SSB
List: \$498.00
Price: \$398.00

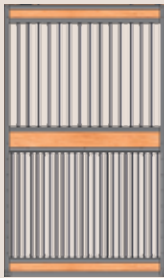

FULL GRILL DOOR
You can see everything that is going inside of the stall with the full grill.

Galvanized Door
Item #SSG
List: \$372.00
Price: \$298.00



FULL GRILL V-DOOR
Full view, full ventilation, and socialization.

Galvanized Door
Item #SSH
List: \$620.00
Price: \$496.00

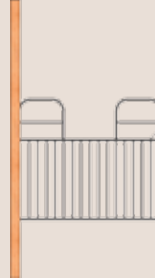

HALF SWING GRILL GATE
Gossip gate allows socialization for your horses with other horses.

Galvanized Gate
Item #SSC
List: \$339.00
Price: \$269.00

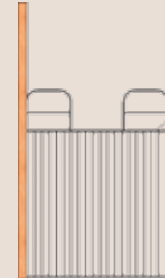

FULL SWING GRILL GATE
Larger version of the half swing grill gate. Gate is 65" in height.

Galvanized Gate
Item #SSD
List: \$479.00
Price: \$378.00

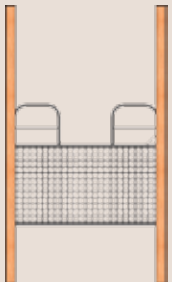

HALF SWING MESH GATE
Heavy duty swing gate with 2" x 2" mesh grid for improved ventilation and socialization.

Galvanized Gate
Item #SSE
List: \$379.00
Price: \$298.00

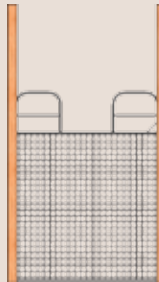

FULL SWING MESH GATE
Larger version of the half swing mesh gate. Gate is 65" in height.

Galvanized Gate
Item #SSF
List: \$479.00
Price: \$378.00



STEP 3: Select the hardware



SQUARE TRACK HARDWARE
Complete hardware kit. Includes trolley, brackets, wall and post bumpers, stay roller, lifting rod and top latch catch. Also includes 8 ft. long square track, (not pictured).

Galvanized
Item #DHKSL-15
List: \$219.00
Price: \$178.00



ROUND TRACK HARDWARE
Complete hardware kit. Includes trolley, brackets, wall and post bumpers, stay roller, lifting rod and top latch catch. Also includes 8 ft. long round track, (not pictured).

Galvanized
Item #DHKRL-15
List: \$269.00
Price: \$219.00



SWING GATE HINGE KIT
Comes with 2 hinges, and 2 pins to attach the swing gate to wooden posts.

Galvanized
Item #1301
List: \$24.98
Price: \$19.98

SWING GATE LATCH KIT
Includes quick latch and splice link to keep your swing gate closed.

Galvanized
Item #1302
List: \$12.48
Price: \$9.96

STANDARD GRILLED PARTITION



10 ft. Grilled Partition
Item #SS10GP-110
List: \$310.00
Price: \$248.00

12 ft. Grilled Partition
Item #SS12GP-135
List: \$349.00
Price: \$278.00

- Safer for your horses - closest 3.25" bar spacing on center
- Many ways to customize, ie. covered edges
- Stays great looking - corrosion resistant, self-latching
- Easy installation in new or existing facilities
- Good rust protection - galvanized, 14-gauge body
- Wood not included - but available for purchase

Wood not included on all stall systems. Wall brace shown comes with 12' size only. All prices subject to change without notice. Call for quantity pricing.

CONTACT US TODAY FOR YOUR FREE ESTIMATE!

Toll Free: 1-800-853-1611 - Fax: 419-825-2433 - Email: ramm@rammfence.com

RAMM Stalls & Horse Fencing

STALL ACCESSORIES

GRILL WORK FOR STANDARD STALLS

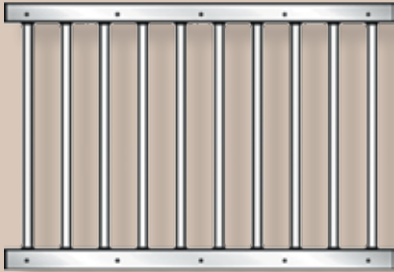

Easily assembled kits for stalls, doors, etc. Includes channeling, bars, and grommets. Screws sold separately.

SIZE	PART #	LIST	PRICE
26"	26GW-19	\$57.00	\$44.00
48"	48GW-35	\$99.00	\$79.00
65"	65GW-47	\$124.00	\$98.00
72"	72GW-53	\$149.00	\$114.00
91"	91GW-66	\$199.00	\$158.00

FEED DOOR FOR THE STANDARD STALLS

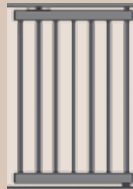

Feed and water your horse from outside of the stall. Great time saver for farm hands.

Galvanized
#FD
List: \$209.00
Price: \$169.00

FEED OPENING FOR THE STANDARD STALLS



An economical way to be able to feed your horse from outside of the stall.

Galvanized
#FO
List: \$26.00
Price: \$19.84

48" GRILL SECTION WITH V-DROP DOWN DOOR

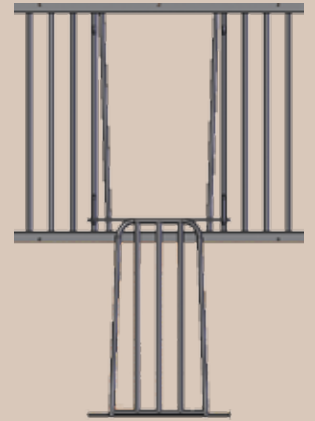

V-door that allows your horse freedom to socialize with other horses.

Galvanized
#48VSD
List: \$248.00
Price: \$199.00

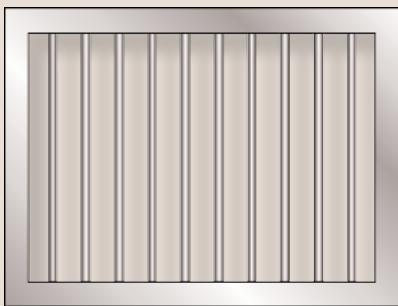

GRILLED WINDOW FRAME WITH WELDED BARS

Angle iron around frame measures 1/2" smaller than opening. Bars are welded. Requires 8 screws for assemble, not included.

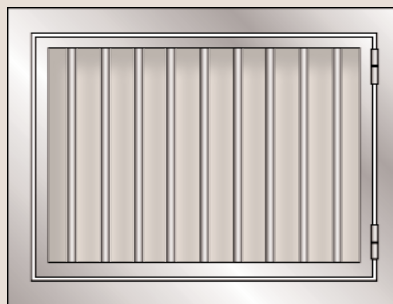

HINGED GRILLED WINDOW INSERT

Frame with hinged grill section. Quickly installs with 8 screws, not included. Angle iron around frame measures 1/2" smaller than opening.

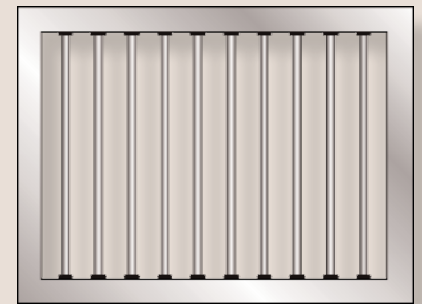

GRILLED WINDOW KIT

This kit can be cut on site for odd sized. Angle iron around frame measures 1/2" smaller than opening. 8 screws included. Galvanized only.

SIZE	PART #	LIST	PRICE
36"Wx24"H	3624WG (W.B.)	CALL	CALL
24"Wx36"H	2436WG (W.B.)	CALL	CALL
32"Wx36"H	3236WG (W.B.)	CALL	CALL
36"Wx36"H	3636WG (W.B.)	CALL	CALL
36"Wx48"H	3648WG (W.B.)	CALL	CALL
48"Wx36"H	4836WG (W.B.)	CALL	CALL
48"Wx48"H	4848WG (W.B.)	CALL	CALL

SIZE	PART #	LIST	PRICE
36"Wx24"H	3624WGH (W.B.)	CALL	CALL
24"Wx36"H	2436WGH (W.B.)	CALL	CALL
32"Wx36"H	3236WGH (W.B.)	CALL	CALL
36"Wx36"H	3636WGH (W.B.)	CALL	CALL
36"Wx48"H	3648WGH (W.B.)	CALL	CALL
48"Wx36"H	4836WGH (W.B.)	CALL	CALL
48"Wx48"H	4848WGH (W.B.)	CALL	CALL

SIZE	PART #	LIST	PRICE
36"Wx24"H	3624WG	\$105.00	\$84.00
24"Wx36"H	2436WG	\$130.00	\$104.00
32"Wx36"H	3236WG	\$149.00	\$118.00
36"Wx36"H	3636WG	\$156.00	\$124.00
36"Wx48"H	3648WG	\$156.00	\$124.00
48"Wx36"H	4836WG	\$174.00	\$138.00
48"Wx48"H	4848WG	\$186.00	\$148.00

All prices subject to change without notice. Call for quantity pricing.

RAMM Stalls & Horse Fencing

SLIDING DOOR TRACK HARDWARE

SQUARE TRACK HARDWARE

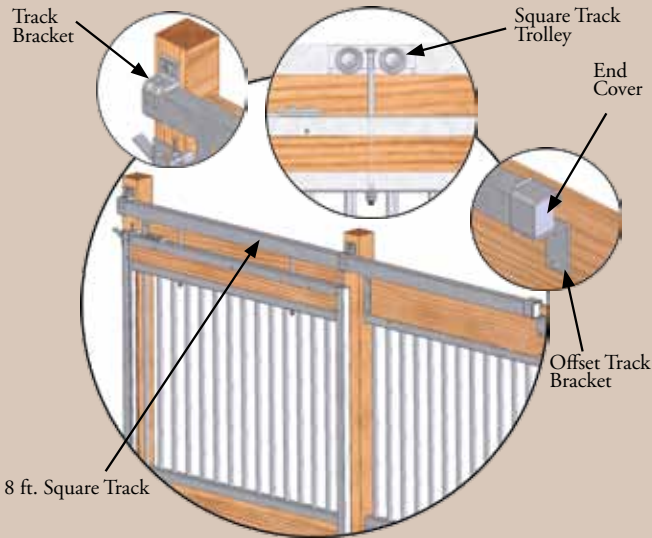

ROUND TRACK HARDWARE

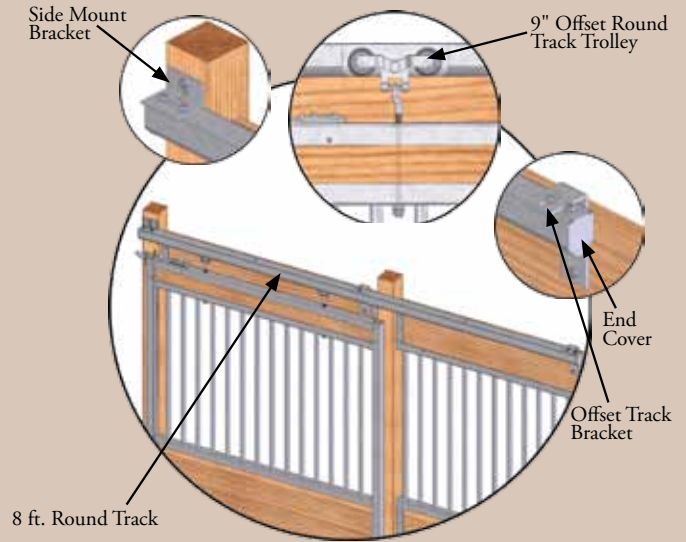

DESCRIPTION	ITEM #	LIST	PRICE
SQUARE TRACK			
8ft Track - Galv	8ST-14	\$37.00	\$29.00
90 deg SQ Track trolley - Galv (ea.)	STT90-3	\$51.28	\$34.98
SQ track trolley - Galv (ea.)	STT-2	\$43.95	\$29.98
SQ track bracket - Galv	STB-1	\$8.72	\$6.98
SQ offset track bracket - Galv	OTB-2	\$11.23	\$8.98
SQ End Cover - Galv	STEC-1	\$3.73	\$2.98
Straight Trolley Bolt - Galv	TB1212	\$12.98	\$9.98

DESCRIPTION	ITEM #	LIST	PRICE
ROUND TRACK			
8ft Track - Galv	8RT-14	\$49.98	\$39.98
90 deg Round Trolley - Galv (ea.)	RTT90-3	\$56.29	\$44.98
RT Trolley off-set - Galv (ea.)	RTTO-3	\$56.29	\$44.98
RT Side Mount Bracket - Galv	RTSB-2	\$8.75	\$6.98
RT Offset track Bracket - Galv	ROTB-2	\$16.29	\$12.98
RT End Cover - Galv	RTEC-1	\$4.49	\$3.49

SQUARE & ROUND TRACK	ITEM #	LIST	PRICE
Wall Bumper - Galv	WB-2	\$16.27	\$12.98
Post Bumper - Galv	PB-2	\$16.27	\$12.98
Stay Roller - Galv	SR-2	\$21.29	\$16.98
Adjustable Stay Roller - Galv	ASR-4	\$34.99	\$27.98
Offset Trolley Bolt - Galv	OTB129	\$12.98	\$9.98

DESCRIPTION	ITEM #	LIST	PRICE
COMPLETE HARDWARE KIT: Includes trolley, brackets, wall and post bumpers, stay roller, lifting rod, track and top latch catch.			
Square Track Hardware Kit - Galv	DHKSL-15	\$219.00	\$178.00
Round Track Hardware Kit - Galv	DHKRL-15	\$269.00	\$219.00



SQUARE TRACK TROLLEY

Trolley bolt not included.



SQUARE TRACK TROLLEY 90 DEGREE



ROUND TRACK TROLLEY

Trolley bolt not included.



ROUND TRACK TROLLEY 90 DEGREE

All prices subject to change without notice. Call for quantity pricing.

CONTACT US TODAY FOR YOUR FREE ESTIMATE!

Toll Free: 1-800-853-1611 - Fax: 419-825-2433 - Email: ramm@rammfence.com

STALL CHANNELING

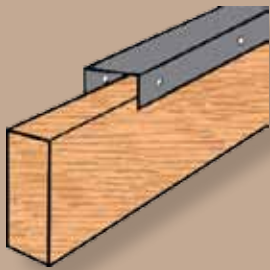

WALL CAPPING

Helps protect wall tops from damage. Assembly requires 16 screws, not included. Measures 1.5" x 1.5" with 1.75" opening. Screws sold separately.

96" Item #WC8-5 (Galvanized)

List: \$17.50 Price: \$13.98



WALL BRACES

Used to brace wall boards 8' and over. Assembly requires screws, not included. 18-gauge. Screws sold separately.

46.5" Item #46W-5 (Galvanized) 9 screws

List: \$12.50 Price: \$9.98

94.5" Item #94W-9 (Galvanized) 18 screws

List: \$22.50 Price: \$17.50



POST EDGING

Protects posts from damage. Assembly requires 14 screws, not included. Measures 1" x 1". Screws sold separately.

96" Item #PE-8 (Galvanized)

List: \$12.50 Price: \$9.98

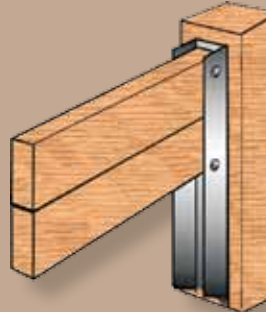

U-CHANNELS

Used to support wallboards between posts. Screws required for assembly not included. Measures: 1.75" x 1.75" with 1.5" opening. Screws sold separately.

7" Item #7U-1 (Galvanized) 9 screws

List: \$6.25 Price: \$4.98

46.5" Item #46U-6 (Galvanized) 24 screws

List: \$18.50 Price: \$14.90

94.5" Item #94U-10 (Galvanized) 39 screws

List: \$32.50 Price: \$26.00



GALVANIZED STEEL SCREWS

#12 - 1 1/4" long galvanized steel screws. For attaching stall channeling to wooden stall posts and boards.

Item #SS1-1

Price: \$6.98 / 50 pk.



All prices subject to change without notice. Call for quantity pricing.

RAMM Stalls & Horse Fencing

WELDED STALLS

Other stall welds can have sharp burrs that can cut your horse. RAMM's quality welds are hidden and smooth adding strength, safety and beauty to your stalls. Each bar is placed through the pre-punched holes in the u-channel then welded securely in place. Whether your barn colors are black, hunter green, navy blue, burnt orange or any other color, we have you covered with our custom powder-coating colors. Call us today for more information.

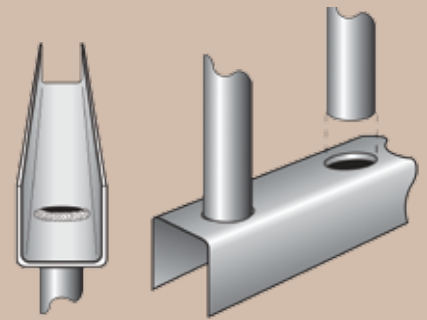

MANY FRONT AND DOOR OPTIONS TO CHOOSE FROM...



TO MEET WHATEVER YOUR NEEDS ARE !

HIGH-GRADE

PRECISION

SAFETY



CALL US FOR PRICING ON OUR WELDED STALL FRONTS AND PARTITIONS.

CONTACT US TODAY FOR YOUR FREE ESTIMATE!

Toll Free: 1-800-853-1611 – Fax: 419-825-2433 – Email: ramm@rammfence.com

CUSTOM STALLS

TALK TO US ABOUT DESIGNING THE PERFECT STALLS FOR YOUR HORSES !



Custom Tuscany Stalls



Custom Welded Stalls



Custom Nobleman Stalls



Custom Milano Stalls



Custom Nobleman Stalls



Custom Tuscany Stalls

CUSTOM STALL PARTITIONS

- Can be custom fit to any size
- Can be galvanized or powder coat painted
- Made of 12-gauge heavy-duty wall material for framing
- Can be built as a grilled partition - For better ventilation
- Can be built as a solid partition - For privacy
- Can be built as a partial grilled, partial solid partition -
For feeding and/or watering
- Constructed to be used with any stall systems

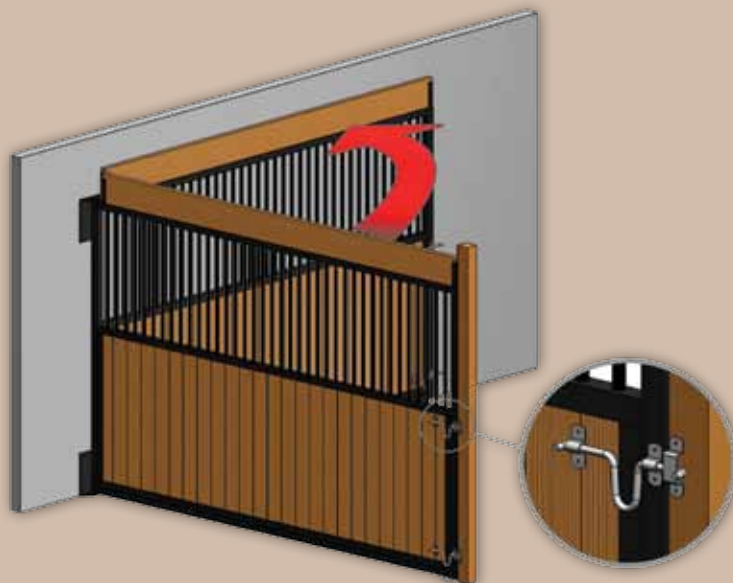

Wood not included on all stall systems. All prices subject to change without notice. Call for quantity pricing.

INTERLOCKING RUBBER PAVERS



- Simple and Attractive
- Anti-Fatigue Protection
- Cushions Horse's Hooves
- 3-Year Limited Warranty
- 100% Rubber Paver
- Dog Bone Shape
- Durable in All Weather Conditions
- Anti-Slip Protection Design
- Durable and resilient construction
- Installation is a breeze
- Combine with multiple pavers to create an infinite array of shapes
- Easily Cleaned
- Available in either 1" or 1 3/4" Thick paver
- Comes in either Terra Cotta, Hunter Green or Black



DESCRIPTION	COLOR	OUR PRICE
1 inch Thick	Terra Cotta, Hunter Green or Black	CALL
1 3/4 inch Thick	Terra Cotta, Hunter Green or Black	CALL

All prices subject to change without notice. Call for quantity pricing.

CONTACT US TODAY FOR YOUR FREE ESTIMATE!

Toll Free: 1-800-853-1611 – Fax: 419-825-2433 – Email: ramm@rammfence.com

THUROBED MATTRESS SYSTEM™



- HEALTHIER ENVIRONMENT FOR YOUR HORSE—less bedding needed, less dust
- Speeds recovery time - mats are 3" thick
- EASIER TO HANDLE THAN OTHER SYSTEMS—smaller, lighter mattresses are easier to install
- Environmentally friendly
- SAVE ON BEDDING AND LABOR without sacrificing your horse's comfort
- REDUCES YOUR MANURE PILE!
- Stainless steel screws sold separately, but required to attach fastening strips to stall walls

ThuroBed mattress system™ components



- A** Heavy Duty Fastening Strips
- B** One-Piece Top Cover
- C** Resilient Mattresses



DESCRIPTION	ITEM #	OUR PRICE
12' x 12' System	SC1212	\$728.00
10' X 12' System	SC1012	\$628.00
10' x 10' System	SC1010	\$568.00

All prices subject to change without notice. Call for quantity pricing.

STALL MATS

RUBBER STALL MATS



- 10-year limited warranty
- Non-skid surface with a corrugated bottom
- 4' x 6'
- 3/4" thick vulcanized rubber
- Cushions horse's feet and legs
- Reduces bedding costs
- Heavy Duty and long lasting
- Easy installation

Item #46SM-102
Price: \$39.00

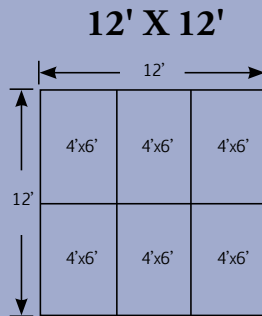
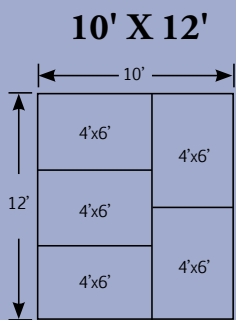
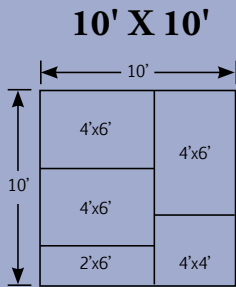

INTERLOCKING RUBBER MATS



2'x2' Rubber Mat - Has tabs on all sides of the mat
Item #SMI8-27
Price: CALL

4'x6' Rubber Mat - Has tabs on right and bottom
Item #SMI10L-102
Price: \$58.00

4'x6' Rubber Mat - Has tabs on left and bottom
Item #SMI10R-102
Price: \$58.00

4'x6' Rubber Mat - Has tabs on left, right and bottom
Item #SMI14-102
Price: \$58.00

4'x6' Rubber Mat - Has tabs on right, top and bottom
Item #SMI16-102
Price: \$58.00

4'x6' Rubber Mat - Has tabs on all sides of the mat
Item #SMI20-102
Price: \$58.00

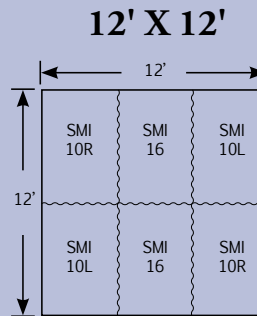
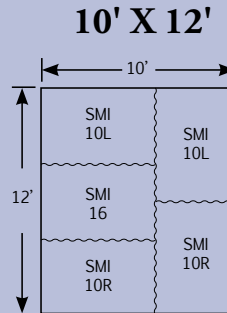

WASH MATS



3' x 5', 1/2" thick
Item #35WM-35
Price: \$39.00

RAMM TIP

Clean your stall mats like you would clean your vinyl floors by using any common, household all-purpose cleaner. Follow the manufacturer's label instructions and do not use heavily concentrated bleach or ammonia-based products.

All prices subject to change without notice. Call for quantity pricing.

CONTACT US TODAY FOR YOUR FREE ESTIMATE!

Toll Free: 1-800-853-1611 - Fax: 419-825-2433 - Email: ramm@rammfence.com

WATERERS & BUCKETS



FLEXIBLE STALL WATERER

An innovative, flexible waterer. Made in Germany utilizing brass valves. Will not stick open like water float valve systems.

Item #FHW-4

Price: \$69.00



LOCKABLE STALL WATERER

Plastic with brass valves. Allows you to shut off the flow of water right at the paddle. Horses must push on paddle for water.

This design wastes less water and the bowl stays cleaner.

Item #LHR-4

Price: \$74.00



SWING OUT BUCKET DOOR

Allows you to water from the aisleway instead of going into the stall. This heavy-duty door is big enough to hold a 5-gallon bucket with a standard bucket holder, or our insulated 5-gallon bucket and holder (not included). Slide-bolt latch keeps door closed tight. Galvanized steel. Measures 18.5" x 22".

Item #SBHD(B,G)-26

**Price: \$99.00 Galvanized
\$159.00 Painted**



INSULATED BUCKET HOLDER

Keeps water from freezing in winter, and cooler in summer. Includes a 5-gallon poly pail with float. Can be added into a swing-out bucket door, or mounted directly on the stall wall.

Measures 16" x 18" x 16"

Item #PHSW-11

Price: \$91.20



AUTO STALL WATERER

- Mount on stall wall
- Removable drain plug for easy cleaning
- Made of heavy-duty polyethylene
- Wall filled with extra urethane insulation
- Rounded edges for safety
- Adjustable height drinker
- Heater turns on at 42 degrees/off at 52 degrees
- Measures 12" x 14" x 41"

Item #ASWH-11

Price: \$216.50



PAIL SAFE BUCKET HOLDER

Virtually horse proof, and people friendly. For use with any flat-back bucket.

Black only. Bucket sold separate.

Item #PSB-1

Price: \$24.00



5-GALLON BUCKET HOLDER

Fasten using lag bolts, or for more strength, bolt right through stall wall (fasteners not included). Available in red, or custom match your welded, painted stall system. Bucket not included.

Item #BH5-5

Price: \$19.98



5-GALLON FLAT-BACK HEATED BUCKET

One of our best selling buckets. Keeps water from freezing in the winter. Caution: If unit is unplugged, water will freeze. Remove ice before plugging unit in again. Six-foot shielded cord protects horses from chewing. One-year limited warranty.

Item #EBB-6

Price: \$39.98



16-GALLON HEATED BUCKET

Thermostatically controlled to keep water approximately 42 degrees. The 260 watt heater is energy efficient, and the 6' shielded cord protects horses from chewing. Caution: Put in a sheltered area and stabilize bucket for use on very cold days. Blue only. One-year limited warranty.

Item #16EB-9

Price: \$69.98



INSULATED WATERER WITH OPTIONAL HEATER

- Insulated unit utilizes a 100-watt infrared heater
- Auto fill valve
- Wall filled with urethane insulation
- Made of high-density polyethylene
- Removable drain plug for easy cleaning
- Made from a single, solid polymer shape, so there's no chance of electric shock through the water
- Heater turns on at 42 degrees/off at 52 degrees
- Measures 22" x 10" x 48"
- 5 Gallon tank, up to 6 horses

Item #WPHI-37

Price: \$380.00

All prices subject to change without notice. Call for quantity pricing.

RAMM Stalls & Horse Fencing

FEEDERS & HAY RACKS



WALL MOUNT HAY RACK

Can be mounted on a partition or back wall of your stall. Measures 32" wide, 7" deep and 32" high. Powder-coated black or galvanized. Item #HRW(galv) or HRWB(black)
Price: \$42.00



CORNER HAY RACK

Corner feeder holds 2 or 3 flakes of hay and allows dust to fall. Powder-coated black or hot-dipped galvanized. Measures 32" wide, 7" deep and 28" high. Item #HRC-11
Price: \$42.00



POLY CORNER GRAIN FEEDER

Helps prevent horse from throwing, pushing or spilling feed. Smooth, rounded edges prevent injury. The entire feeder measures 16" high by 24" wide. Feed opening is 9.75" deep and 12" across. Item #PHGF-3
Price: \$22.15



POLY CORNER FEEDER

Made of PolyTuff material, this feeder/hay rack will stand up to the toughest demands. Can be bolted into a corner or put onto a corner swing out door. Measures 21" x 35". Item #PCF-28
Price: \$169.50
*Note: This only fits the large feed door.



GALVANIZED CORNER MOUNT FEEDER

Strong corner mount unit ships in a kit for easy assembly. Measure 25" wide, 17" deep and 6" high. Item #CFP-16
Price: \$69.00



GALVANIZED WALL MOUNT FEEDER

Easy to assemble and very strong with bottom brace. Ships compact and includes all hardware. Safety edges on all metal components. Measures: 20" wide, 13" deep and 6" high. Item #WFP-17
Price: \$69.00



GALVANIZED CORNER HAY RACK

Combination hay and grain feeder. Measures 36" wide, 22" deep and 32" high. Item #CFHR-66
Price: \$199.00



GALVANIZED WALL HAY RACK

Mounts on any flat surface either on a partition or back wall of your barn. Measures 24" wide, 18" deep and 32" high. Item #WFHR-61
Price: \$188.00

TACK ACCESSORIES



BLANKET BARS

Holds blankets, sheets, halters, etc. Steel bar measures 40.5" long. Item #BB-5
Price: \$28.88



FOLDING SADDLE RACK

This sturdy folding saddle rack with welded construction mounts easily to any flat surface and comes with built-in bridle hook. Stores your saddle in the correct position and conveniently folds down when not in use. Item #SADRACK-6
Price: \$59.00



Rat Zapper

- Larger chamber than the Rat Zapper Classic
- Bait with ordinary pet food.
- Mice and rats enter the chamber and are dispatched with a quick but powerful jolt of electricity.
- Humanely gets rid of mice, rats and other rodents. If they'll fit in the chamber, Rat Zapper will dispatch them!
- No blood, no gore, no mess, and no poisons to endanger your pets or the environment
- Flashing kill light tells you when you have a catch; simply tip the Rat Zapper and let the dead rodent slide into the trash can. Item #RZU-2

Price: \$59.99

All prices subject to change without notice. Call for quantity pricing.

CONTACT US TODAY FOR YOUR FREE ESTIMATE!

Toll Free: 1-800-853-1611 – Fax: 419-825-2433 – Email: ramm@rammfence.com

CLASSIC CRAFTED DOOR HARDWARE

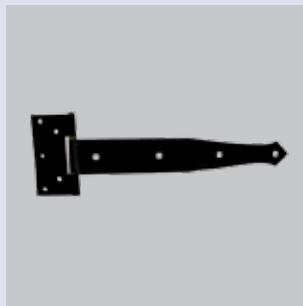

HEAVY DUTY STRAP HINGE

12" strap hinge. 1/4" thick x 2" wide, with 4.5" x 1-5/16" mounting plate. Black.

Item #HINGE03-3
List: \$95.00
Price: \$76.00



HEAVY DUTY HINGES

16" strap hinge with a 1" offset back into door opening. 3/16" thick x 2.5" wide x 16" long with a 6" x 2.75" mounting plate. Black.

Item #HINGE16-5
List: \$162.00
Price: \$129.00



GRIP LATCH

For swinging doors. Right or left use. Pistol grip on other side of latch. For use with doors up to 3" thick. Bar size 1.5" x 5/16" x 14". Black enamel fasteners included.

Item #DL125-7
List: \$149.00
Price: \$119.00



THUMB LATCH

Can be used with 1.75"-2.75" thick door. Cast iron, zinc plated. Doors can open from either side with this latch.

Item #DLTL-3
List: \$89.00
Price: \$71.00



FLUSH MOUNT LOCK LATCH

For swinging or sliding doors. Combination lock and latch. Operated from either side of door. For doors up to 2" to 5" thick. Bar size 1.5" x 5/16" x 14". Black enamel.

Item #DL152-6
List: \$183.00
Price: \$147.00

Elegant door hardware will give your barn a one of a kind style. Heavy duty hand-crafted look with a classic carriage house design. We all know how details can really make the difference and RAMM's door hardware will make a statement in your barn. Heavy duty, made to last in your barn, stable or boarding facility.

It's all in the details. Give the finishing touches to your horse barn with classic crafted door hardware from RAMM.



HD FLUSH HANDLE

Heavy-duty flush handle that installs flush into a sliding door. Black painted cast iron. Pocket measures 4-3/8" high x 3.75" wide x 1.75" deep.

Item #DLFPHD-3
List: \$110.00
Price: \$88.00



FLUSH PULL HANDLE

Goes flush onto a sliding door. Formed steel, galvanized construction. Pocket measures 4.5" high x 1-3/8" wide x 1.25" deep.

Item #DLFP-1
List: \$25.00
Price: \$20.00



TOP SPRING BOLT

Self-closing for the top of a Dutch door or double door system. 36" long chain with ring included. Zinc plated. Housing is 5.5" high x 2-7/8" wide with a beveled bolt.

Item # DLSSB-F3-3
List: \$88.00
Price: \$77.00



DOOR SNUGGER

Keeps doors tightly closed. Fits most sliding doors. Easy to install, zinc plated. Not accessible from outside. Measures 1.5" x 15".

Item #DLDS-4
List: \$54.50
Price: \$44.00



CANE BOLT

Used to anchor bottom of door in place when two doors meet and only one is primarily used. Formed bar steel with holding brackets. Zinc plated.

1/2" x 12" Item #DLCB-2
List: \$64.00
Price: \$51.00
3/4" x 24" Item #DLCB24-5
List: \$85.00
Price: \$68.00

Special order items. Non-returnable. All prices subject to change without notice. Call for quantity pricing.

HORSE STOCKS



- **VERSATILE**—use for grooming, shoeing, bathing, vet checks, etc.
- Available in Hot Dipped Galvanized or Powder Coat Painted
- Frame is 7-gauge steel, door is 12-gauge steel
- Includes Southern Yellow Pine - priced with wood
- Tie Rings Included, cross-tie rings on each corner
- Bolts to concrete floor easily; cross ties ring corners
- One-year limited warranty
- Door uses slide bolt latch; with adjustable rails

HORSE STOCKS

Horse stocks are great whenever you need an extra set of hands! If you have a horse that doesn't stand well for clipping, bathing, shoeing, grooming, vet checks, etc., then use a horse stock to gently keep your horse in place. Tie rings are located both inside and out, so you and your horse will be in a safer situation. Your vet and farrier will appreciate it as well!

DESCRIPTION	ITEM #	OUR PRICE
Horse Stock - Galv	HS-500	\$1498.00

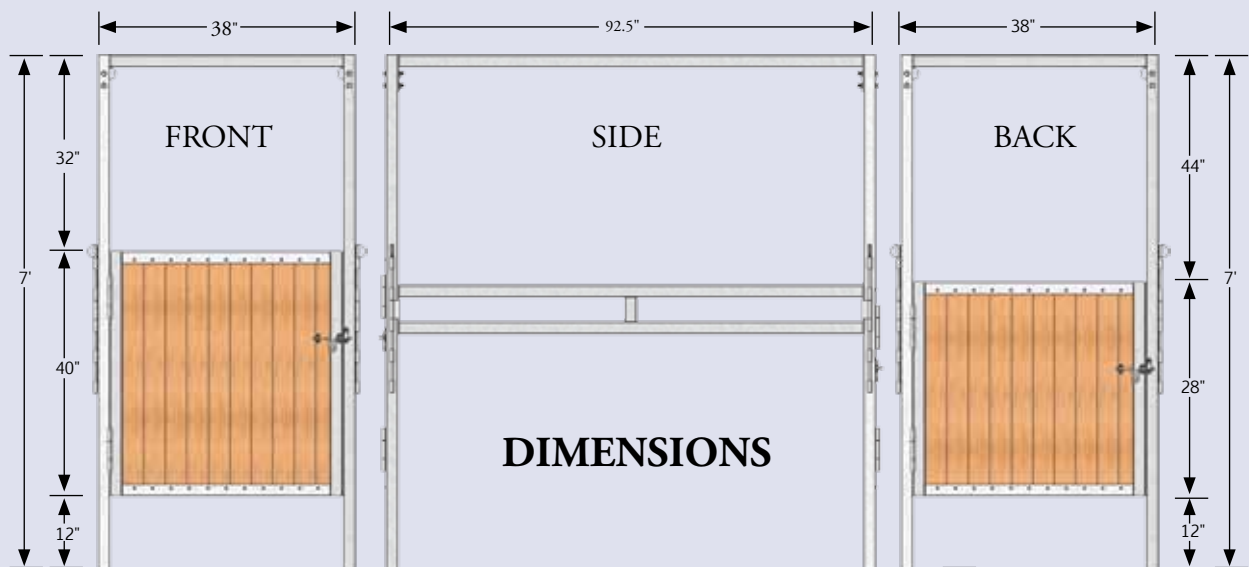

All prices subject to change without notice. Call for quantity pricing.

CONTACT US TODAY FOR YOUR FREE ESTIMATE!

Toll Free: 1-800-853-1611 – Fax: 419-825-2433 – Email: ramm@rammfence.com

TRACK & RING CONDITIONER



RAMM Track and Ring Conditioner is the ultimate way to level, drag and condition your arena - all in one. Choose a 3 point hitch model or a pull behind conditioner made for garden tractors.

- **Built to last**
- **Track conditioning made easy!**
- **For large or small track, rings and arenas**
- **Easy to maneuver in tight corners**
- **Moves enough material to fill in holes and take out high spots**
- **Blade angles up to 30 degrees**
- **Blade has adjustable pitch**
- **6' & 8' blade sizes available**



A-frame design for added strength. Welded components and highly visible red powder-coating add durability.



Quick release draw pins make things quick and easy to connect the track and ring conditioner to any tractor.



Able to adjust both the blade pitch and the blade angle quickly with the supplied quick release draw pins.



Change the depth of the tines with 6 different settings.

TRACK & RING CONDITIONER		
Choose between our 6 ft. or 8 ft. wide blade. Recommended use with 20 to 60 HP tractor with category 1 three-point hitch.		
DESCRIPTION	ITEM #	OUR PRICE
6' Blade	DRAG6-316	\$1,478.00
8' Blade	DRAG8-350	\$1,688.00

TRACK & RING REPLACEMENT PARTS



Tine Assembly

Agricultural tines penetrate into the soil better and more consistently than rods or spikes.

Item # TWP-3 \$17.95



Tine tooth

Double ended for twice the life. Made to dig into packed soil. 6.5" tine tooth.

Item #TP-1 \$5.50



Heavy Duty Tine Tooth

Double ended for twice the life. Heavy duty 7.5" tine tooth for superior penetration.

Item #TPHD-1 \$6.50



Tine Bracket

Used to attach the tine onto flat bar.

Item #TB-1 \$5.99



Tine Nut & bolt

Special bolt and nut to attach the tine tooth to the tine.

Item #TNB-F3 \$1.25

All prices subject to change without notice. Call for quantity pricing.

RAMM Stalls & Horse Fencing

TRACK & RING CONDITIONER



PULL BEHIND CONDITIONER

- Can be pulled behind large garden tractors, ATV's, Cars, Trucks, and Gators
- For large or small tracks, rings and arenas
- Easy to maneuver in tight corners
- Easy hook up to equipment
- Wheel kit for travel over grass & driveways
- Blade angles up to 30 degrees
- Blade has adjustable pitch
- 4', 6' & 8' blade sizes available

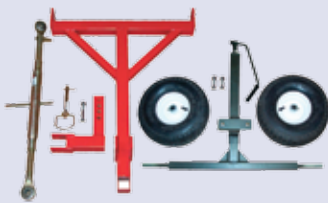

PULL BEHIND KITS
 Pull Behind Kits can be purchased separately if you have an existing Track & Ring Conditioner
 Item #WHEELKIT-105
Price: \$578.00

TRACK & RING PULL BEHIND

This model is designed to be towed behind almost any vehicle with sufficient power.

DESCRIPTION	ITEM #	OUR PRICE
4' Blade	DRAG4 & WHEELKIT-300	\$1,835.00
6' Blade	DRAG6-& WHEELKIT-425	\$1,900.00
8' Blade	DRAG8-& WHEELKIT-455	\$1,990.00

ARENA FOOTING TREATMENT



RAMM Arena Conditioner - An Innovative Solution to Create a Cleaner Environment for Horse and Rider. RAMM Arena Conditioner is an odorless, non-toxic and non-hazardous cross-linked, acrylamide co-polymer.

RAMM Arena Conditioner acts like a "super-sponge", absorbing and storing nearly two hundred times its dry weight in water, releasing the moisture into the arena surface as needed. A moist surface will control dust and give the arena a more consistent and softer texture and create a cleaner, less dusty environment for both horse and rider.

RAMM Arena Conditioner is worked into the arena surface and then watered. The water absorption capacity of RAMM Arena Conditioner allows watering requirements to be reduced, and in some cases cut in half.



Absorbs & Holds H2O

DESCRIPTION	ITEM #	OUR PRICE
RAMM Arena Conditioner - 8 lbs. bag	TS10	\$61.52
RAMM Arena Conditioner - 50 lbs. bag	TS55	\$298.00

All prices subject to change without notice. Call for quantity pricing.

CONTACT US TODAY FOR YOUR FREE ESTIMATE!

Toll Free: 1-800-853-1611 – Fax: 419-825-2433 – Email: ramm@rammfence.com

RAMM Stalls & Horse Fencing

FLY CONTROL SYSTEM

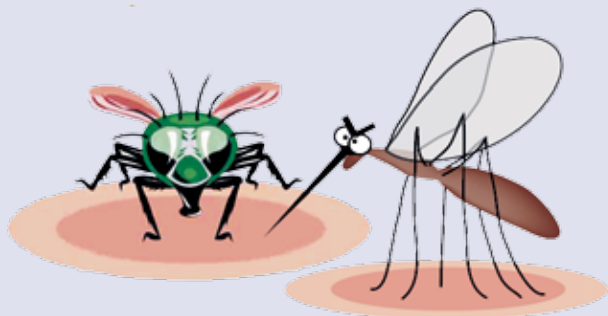

KEEP THOSE PESTS AWAY FROM YOUR HORSES & FAMILY!

With our Fly & Mosquito Control Systems, flies, mosquitoes and many other insects are eliminated in 60 seconds using natural, safe fly control products. The insecticides are not harmful to you, your family, your animals or the environment!

Systems can be used for your horse barn, pool, patio or home. Great for humid areas or those who live near lakes!

- INSECTICIDES ARE BIODEGRADABLE
- Custom systems available
- APPROVED FOR USE AROUND HUMANS AND ALL WARM BLOODED ANIMALS
- MEETS ALL REQUIREMENTS OF THE ENVIRONMENTAL PROTECTION AGENCY
- KILLS INSECTS SO QUICKLY IT INTERRUPTS THE BREEDING CYCLE
- Comes with a 2-year limited warranty
- INSECTS CANNOT DEVELOP IMMUNITY TO THIS FORMULA!

We offer complete systems, individual parts and pieces and insecticide refills. Call for available items and prices.

A SATISFIED CUSTOMER:

"Not only does your product rid our barn of flies/mosquitoes, it keeps our barn smelling fresh. I have had several clients/visitors comment on the refreshing scent of your fly spray. We are very happy with your company and will recommend it to anyone."

- Roslyn Ft. Worth, TX

All prices subject to change without notice. Call for quantity pricing.



AUTOMATIC FLY & MOSQUITO PACKAGE

55 Gallon analog timer package
Flexible package that will fit many different applications.
Great for do-it-yourselfers!

Item #AFSK
Price: \$1329.00

The package includes the following items:

1 - 55 gallon black reservoir w/removable lid and locking ring	1 - 1/4" Union tee
1 - 1/3 HP Motor	1 - 1/4" Union connector
1 - 140 GPM Pump	4 - 1/4" Union elbow
1 - Analog timer	1 - Fitting tool
1 - Black weather-proof cover	1 - Tubing cutter
10 - Tee nozzle assemblies	1 - In-line filter
2 - Elbow nozzles assemblies	1 - Hose end filter
	80 - 1/4" black loop clamp fasteners
	200 - feet of 1/4" black nylon tubing

ACCESSORIES & REPLACEMENT PARTS

Deodorizer Refill:	Item #DO-4	Price: \$32.95
Insecticide Refill:	Item #IS-4	Price: \$119.00



1/4" 90-DEGREE
ELBOW FITTING
Item #9EF
Price: \$4.40



1/4" NOZZLE
WITH TIP
Item #BNT
Price: \$15.40



1/4" NOZZLE
T - FITTING
Item #NTF
Price: \$5.40



1/4" NYLON
TUBING
Item #NT(W,B)
**Price: \$44.00
per 100' roll**



REPLACEMENT
PUMP
Item #RP
**Price:
\$209.00**



PUMP MOTOR
REPLACEMENT
Item #PM
**Price:
\$159.00**



REPLACEMENT
ANALOG TIMER
Item #TIME
**Price:
\$234.00**



1/4" UNION
FITTING
Item #UF
Price: \$4.30

ARENA & STALL LIGHTING

Full spectrum lighting gives your barn a bright day light view! Tightly sealed lights keep dirt and bugs out of fixtures keeping them clean and bright. (Lights include the bulbs). If you are looking for the ultimate lighting for your stalls, barn or arena, RAMM Full Spectrum lighting is for you and your horses!



- Full-spectrum lighting with no glare or no shadows
- 800 watts of light with only 84 watts consumed
- Fiberglass housing designed for wet locations, no rusting parts
- Gasketed to seal out moisture, dust and bugs
- 3 high performance, T8 - 5,000 Kelvin temperature 30,000 hour lamps
- Bulbs last up to 40 times longer than standard incandescent bulbs, saving money

Item #4AG

Price: \$119.00

- 200 watts of light with only 36 watts consumed
- Virtually indestructible flame and rust proof polycarbonate housing
- Instant on at -20°F
- 5,000 Kelvin temperature lamp
- Lamps last up to 13 times longer than a standard incandescent bulb
- Clear diffuser for maximum light output
- Power wash without fear of breakage or water penetration

Item #OAG36HW

Price: \$69.00

A SATISFIED CUSTOMER:

"When we built our barn, I told my husband that I wanted to have stalls and a barn that I could see my horses in, day or night. We installed the RAMM arena and stall lights and I could not believe how much light they produced! It was like day light, even on the darkest nights. I can see my horses, tack and feed clearly with out any strain or white light glare. We decided to install them in our arena and have had several clinics. Every clinician raved about the lighting and told us it was one of the nicest facilities they ever worked in! Thank you RAMM!"

- Kristen F. Bryan, OH

All prices subject to change without notice. Call for quantity pricing.

CONTACT US TODAY FOR YOUR FREE ESTIMATE!

Toll Free: 1-800-853-1611 – Fax: 419-825-2433 – Email: ramm@rammfence.com

RUN-IN SHEDS



Run-In Sheds combine versatility, longevity, safety and low maintenance into one simple package.

The design and use of shelter facilities should promote the health, well-being and good performance of horses throughout all stages of their lives. Natural or constructed shelter areas must offer adequate protection from adverse weather conditions.

Whether horses are out 24/7 or on daily turnout, shelter is important to protect your horses from the elements. Studies have shown that 100 square feet per horse is the optimal size for a run in shed. Most people decide a 10' x 20' three sided shed is good for 1-10 horses as most of the time only a couple of horses use the sheds at any one time.



Shelter areas should be located to avoid adverse effects of predictable natural occurrences, such as flooding, but if this should occur, our Run-In Sheds are ideal as they can be moved very easily.

Pastures, paddocks and feed lots used during cold seasons must have adequate windbreaks to reduce the effects of wind chill.

RUN-IN SHEDS

- Portable Shed or Permanent Shelter
- Will not rot or be chewed
- Pre-engineered square tubular frame
- Hot-dipped galvanized finish
- Can be easily converted into stalls or divided by installing a partition
- Assembly required
- Wood is not included, but can be purchased separately through RAMM
- Consider installing feeders and waterers into your run-in shed or shelter to ensure your horse has constant access to fresh food and water



RUN-IN SHED OR SHELTER* (frame only)

Includes: Complete frame, nuts & bolts, and earth anchors.

DESCRIPTION	ITEM #	WEIGHT	OUR PRICE
Run-In Shed 10x10	RI-SHEDFRA10	650 lbs.	CALL
Run-In Shed 10x20	RI-SHEDFRA20	850 lbs.	CALL
Run-In Shed 10x30	RI-SHEDFRA30	950 lbs.	CALL
Run-In Shelter* 10x10	RI-SHELFRA10	575 lbs.	CALL
Run-In Shelter* 10x20	RI-SHELFRA20	875 lbs.	CALL
Run-In Shelter* 10x30	RI-SHELFRA30	1,075 lbs.	CALL



* Run-In Shelter does not include runners.



Holly Oaks Farm
10' x 30' Run-In Shed with optional grill top, mesh bottom stall fronts with feed doors



10' x 20' frame only pictured above



10' x 20' with optional stall fronts with half swing stall gates

Freight F.O.B. Swanton, OH. Installation must comply with manufacturer's specifications. Prices subject to change without notice. Call for quantity pricing.

CONTACT US TODAY FOR YOUR FREE ESTIMATE!

Toll Free: 1-800-853-1611 – Fax: 419-825-2433 – Email: ramm@rammfence.com

DUTCH & BALE DOORS

This 400 year old door style is popular yet today, among barn owners, due to the charm it lends. For practical reasons, the bottom door keeps the animals in or out of the barn as desired. The top door allows for improved ventilation and socialization. Barn doors made of wood often warp due to temperature changes. But RAMM'S steel frame door system resists warping and twisting allowing your door to open and close properly for many years. Add beauty and functionality to your barn! Custom sizes and designs available.



BALE DOOR



BALE WINDOW



SINGLE DUTCH DOOR



DOUBLE DUTCH DOOR

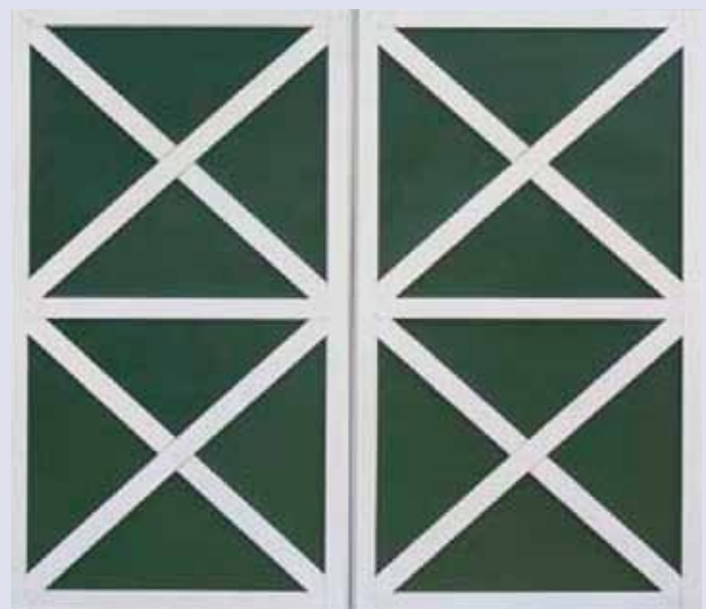

- All doors are built to order
- One piece laser cut design or optional kit form
- Standard D-latch
- 3 piece frame prepped with hinges or optional welded frame
- Window optional on top panel door
- Over 30 colors to choose from
- Aids in ventilation
- Comes in either galvanized or powder-coat painted
- Wood is not included



All prices subject to change without notice. Call for quantity pricing.

CUSTOMER TESTIMONIALS

Ashley P., Wisconsin



"Our experience with RAMM Fence was outstanding! I am a first time horse owner, and I had a lot of questions as to what type of fence would be best for our horses. They were there to answer and help with every question I had. We

chose the 5" High Impact Performance Plus Flex Fence. Every penny was beyond worth it. It looks fabulous, holds up great, and is extremely safe for our horses. We get so many comments on our fence by people we don't even know. They always say your fence is your best investment in your equine set-up and I can honestly say the High Impact is the way to go. We are beyond satisfied! Thank you Ramm Fence!"

Jeff & Shannon S., Illinois



"We recently had the opportunity to fence in our 9 acre property with RAMM's High Impact flex fence. From start to finish, RAMM Fence is a phenomenal company to work with. Christy, who was our salesperson at RAMM did a great job working with us. She would

very kindly price, and re-price the fence we wanted as we continued to redesign it. Christy was so patient and kind, through the whole process. We loved the fact that flex fence would be something we would only have to install on our property once in our life, it was a great feeling! The materials are of impeccable quality and came very quickly. Everything was very well labeled, and the instruction manual had great detail. The fence went up so smoothly. The most impressive part was that it looks just like oak fencing, with the best part being that we never have to paint it! Our whole family helped put up the fence and even our older daughter at 14 years old says that it was a lot of fun."

Taryn F., New Jersey



"I own a 40-acre farm in southern NJ. We had wood fencing and have been slowly replacing the wood with mesh fencing. We have been saying that we need to complete the fencing along our road, but have always put it off to the next year. So we have been

replacing wood boards where the horses rub for over 8 years. I saw the e-mail from RAMM that they were having a fall sale and they had the ElectroBraid™ that I love, but just never thought I could afford. I finally took the leap and boy was it a good leap. We did 4 runs of over 1500 ft and it looks fabulous. I have no idea why we waited so long. This fencing was so easy to install. It makes my fence line look sharp and so attractive. My old wood fencing was so uneven it was embarrassing. Thank you so much Veronica for putting up with all my questions, e-mails, and phone calls. This was so worth the money and I look forward to working with RAMM in the future."

Wade T., Illinois



"We put up the 5" High Impact Performance Flex Fence and were very happy with the ease of installation. The fence looks great, we've had a lot of positive feedback from our neighbors and the community. We also put up Standard Stalls and got great reviews on how professional it looks."

Scott, Michigan



"After over 5 years of use in Michigan, our Flex-Fence still looks as good as new. It was easy to install, durable, and keeps our horses safe. Looking back at the many other fencing solutions, this was a worthwhile investment. Thanks RAMM Fence!"

CONTACT US TODAY FOR YOUR FREE ESTIMATE!

Toll Free: 1-800-853-1611 – Fax: 419-825-2433 – Email: ramm@rammfence.com

**13150 Airport Highway
Swanton, Ohio 43558
Toll Free: 1.800.853.1611
Office: 419.825.2422
Fax: 419.825.2433
Email: ramm@rammfence.com
Website: www.rammfence.com**

CONNECT WITH RAMM



V0512

